



iDCS-8000

Remote Rugged I/O System with Redundancy

Hardware User's Manual



Revision History

Revision	Date	Description of Change
1.43	2013/08/14	Adding pulse input module to this user' s hardware manual
1.42	2013/06/28	Adding analog module to this hardware user' s manual
1.41	2013/06/03	Adding some description for the section of mounting .
1.40	2013/05/22	Document release

Preface

Warranty

All products manufactured by ICP DAS are under warranty regarding defective materials for a period of one year from the date of delivery to the original purchaser.

Warning

ICP DAS assumes no liability for damages resulting from the use of this product. ICP DAS reserves the right to change this manual at any time without notice. The information furnished by ICP DAS is believed to be accurate and reliable. However, no responsibility is assumed by ICP DAS for its use, or for any infringements of patents or other rights of third parties resulting from its use.

Copyright

Copyright © 2013 by ICP DAS CO., LTD. All rights are reserved.

Trademark

The names used for identification only may be registered trademarks of their respective companies.

Table of Contents

SECTION 1 INTRODUCTION	10
1.1 PRODUCT OVERVIEW	10
1.2 FEATURE	11
1.3 HARDWARE STRUCTURE	12
1.4 HARDWARE LIST	13
1.5 INSTALLATION	14
1.5.1 Environment Specification	14
1.5.2 Dimensions	14
1.5.2.1 Module	14
1.5.2.2 iDCS-8000 Body (Module Plugged)	15
1.5.2.3 FRMK (Wall mount panel)	16
1.5.2.4 Termination Board	17
1.5.3 Mounting	20
1.5.3.1 DIN-rail mounting	20
1.5.3.2 Panel mounting	21
1.5.3.3 Wall mounting	22
1.5.4 Module Installation	23
1.5.5 Wiring	24
1.5.6 Field Grounding	25
1.5.6.1 Grounding	26
1.5.7 Terminals and Wiring	28
1.5.7.1 Pluggable Terminal Blocks	28
1.5.7.2 Wiring	29
1.5.8 Cable	29
SECTION 2 POWER MODULES	30
2.1 FPM-D2440	30
2.1.1 Overview	30
2.1.2 Specification	30
2.1.3 Pin Assignment	31
2.1.4 LED Indicator	31
2.1.5 Internal Hardware Structure	32
2.1.6 List of Power Consumption of Module	32
SECTION 3 COMMUNICATION MODULE	33
3.1 FCM-MTCP	33
3.1.1 Overview	33
3.1.2 Specification	33

3.1.3 Switches.....	34
3.1.4 LED Indicators.....	34
3.1.5 Ethernet Port.....	35
SECTION 4 I/O MODULE.....	36
4.1 INTRODUCTION.....	36
4.1.1 LED status.....	36
4.1.2 D-Sub 37 pin connector.....	36
4.1.3 Timing Characteristics.....	37
4.2 DIGITAL INPUT.....	38
4.2.1 F-8040.....	38
4.2.1.1 Overview.....	38
4.2.1.2 Specification.....	38
4.2.1.3 Hardware Structure.....	39
4.2.1.4 Pin Assignment.....	40
4.3 DIGITAL OUTPUT.....	41
4.3.1 F-8041.....	41
4.3.1.1 Overview.....	41
4.3.1.2 Specification.....	41
4.3.1.3 Hardware Structure.....	42
4.3.1.4 Pin assignments.....	43
4.4 ANALOG INPUT.....	44
4.4.1 F-8015.....	44
4.4.1.1 Overview.....	44
4.4.1.2 Specification.....	44
4.4.1.3 Hardware Structure.....	45
4.4.1.4 Pin assignments.....	46
4.4.2 F-8017C1.....	47
4.4.2.1 Overview.....	47
4.4.2.2 Specification.....	47
4.4.2.3 Hardware Structure.....	48
4.4.2.4 Pin assignments.....	49
4.4.3 F-8017C2.....	50
4.4.3.1 Overview.....	50
4.4.3.2 Specification.....	50
4.4.3.3 Hardware Structure.....	51
4.4.3.4 Pin assignments.....	52
4.4.4 F-8017CH.....	53
4.4.4.1 Overview.....	53
4.4.4.2 Specification.....	53
4.4.4.3 Hardware Structure.....	54

4.4.4.4 Pin assignments	55
4.4.5 F-8019	56
4.4.5.1 Overview	56
4.4.5.2 Specification	56
4.4.5.3 Hardware Structure	58
4.4.5.4 Pin assignments	58
4.5 ANALOG OUTPUT	59
4.5.1 F-8028CV	59
4.5.1.1 Overview	59
4.5.1.2 Specification	59
4.5.1.3 Hardware Structure	61
4.5.1.4 Pin assignments	61
4.5.2 F-8028CH	62
4.5.2.1 Overview	62
4.5.2.2 Specification	62
4.5.2.3 Hardware Structure	63
4.5.2.4 Pin assignments	64
4.6 PULSE INPUT	65
4.6.1 F-8084	65
4.6.1.1 Overview	65
4.6.1.2 Specification	65
4.6.1.3 Hardware Structure	66
4.6.1.4 Pin assignments	67
SECTION 5 TERMINATION BOARD	68
5.1 DIGITAL INPUT	68
5.1.1 DN-DIO-M	68
5.1.1.1 Overview	68
5.1.1.2 Specification	68
5.1.1.3 Pin assignment	69
5.1.1.4 Wiring	69
5.1.2 DN-DI-32DW	70
5.1.2.1 Overview	70
5.1.2.2 Specification	70
5.1.2.3 Hardware structure	71
5.1.2.4 Jumper Setting	72
5.1.2.5 Pin Assignment	73
5.1.2.6 Wiring	74
5.2 DIGITAL OUTPUT	76
5.2.1 DN-DIO-M	76
5.2.1.1 Overview	76

5.2.1.2 Specification	76
5.2.1.3 Pin assignment	77
5.2.1.4 Wiring	77
5.2.2 DN-DO-16DR-A & DN-DO-16DR-B.....	78
5.2.2.1 Overview	78
5.2.2.2 Specification	79
5.2.2.3 Hardware structure	80
5.2.2.4 Pin Assignment.....	80
5.2.2.5 Wiring.....	81
5.3 ANALOG INPUT.....	82
5.3.1 DN-AIO-M.....	82
5.3.1.1 Overview	82
5.3.1.2 Specification	82
5.3.1.3 Pin assignment	83
5.3.1.4 Wiring.....	83
5.3.2 DN-RTD-M	84
5.3.2.1 Overview	84
5.3.2.2 Specification	84
5.3.2.3 Pin assignment	85
5.3.2.4 Wiring.....	85
5.3.3 DN-TC-M	86
5.3.3.1 Overview	86
5.3.3.2 Specification	86
5.3.3.3 Pin assignment	87
5.3.3.4 Wiring.....	87
5.3.4 DN-AIH-08	88
5.3.4.1 Overview	88
5.3.4.2 Specification	88
5.3.4.3 Pin assignment	88
5.3.4.4 Wiring.....	89
5.4 ANALOG OUTPUT.....	90
5.4.1 DN-AIO-M.....	90
5.4.1.1 Overview	90
5.4.1.2 Specification	90
5.4.1.3 Pin assignment	91
5.4.1.4 Wiring.....	91
5.5 PULSE INPUT	92
5.5.1 DN-PI-M.....	92
5.5.1.1 Overview	92
5.5.1.2 Specification	92

5.5.1.3 Pin assignment	92
5.5.1.4 Wiring.....	93

Section 1 Introduction

The iDCS-8000 is distributed modular I/O which communicates with numerous controllers. The iDCS-8000 provides easy installation of the I/O modules and process cabling. It is highly modularized and flexible, so that I/O modules can be combined to suit many applications. The iDCS-8000 can be mounted in many configurations to fit most requirements, both in single or fully redundant applications.



1.1 Product Overview

The iDCS-8000 is a modular remote I/O system. It provides easy installation of the I/O modules and process cabling. It is highly modularized and flexible, so that the I/O modules can be combined to suit many applications including the most types of signals, digital, analog, counter and HART.

The station of an iDCS-8000 system consists of power module, communication module, I/O modules and termination board. The power module provides the isolated power to iDCS-8000 system. The communication module is the interface to the iDCS-8000 I/O modules. The iDCS-8000 I/O modules sense or control the device in the field. Termination boards are used to connect between signals to/from the field and I/O modules. All of these modules can be configured into single or redundant operation.

1.2 Feature

The iDCS-8000 is an open comprehensive, distributed, process I/O system. It communicates with controller over industry-standard field buses. It brings benefit for users install to iDCS-8000 in the field, to close to sensors and actuators, to reduce the installation cost by reducing the cost of cabling.

- **Comprehensive**

The iDCS-8000 offers cost-effective solutions to practically all needs for field-device, including basic analog and digital I/O, pulse and HART, as well as high-integrity solutions.

- **Flexible**

The I/O modules plugged in iDCS-8000 station can be configured into single or redundant operation. Users can easily upgrade I/O security in a same station by adding same I/O module and configuring into redundant operation without any additional wiring.

- **Wide industry-standard support**

The iDCS-8000 provides connectivity to most popular industry-standard to communicate with controller, and makes iDCS-8000 I/O compatible with various controller or PLC.

- **The up-to-date I/O**

The I/O modules plugged in the iDCS-8000 station will automatically update I/O data to communication module. This feature not only decreases the delay for updating I/O data but also acquire the up-to-date I/O data.

- **I/O redundant switching < 1ms**

The iDCS-8000 features a tiny time for I/O redundant switching within maximum 1ms.

- **Reliable**

The iDCS-8000 offers availability-improving feature such as:

- Hot swap of modules. A faulty I/O module can be replaced on-line without powering the station down and without affecting the rest of the station.
- The iDCS-8000 system also ensures that only right type of modules can be inserted when to replace on-line.
- Automatically re-configure same parameter when plugging a replaced module.
- Redundancy options in all modules, power, communication, I/O.

1.3 Hardware Structure

The iDCS-8000 is made by the combination of components of the backplane, power modules, communication modules, I/O modules and an termination board.

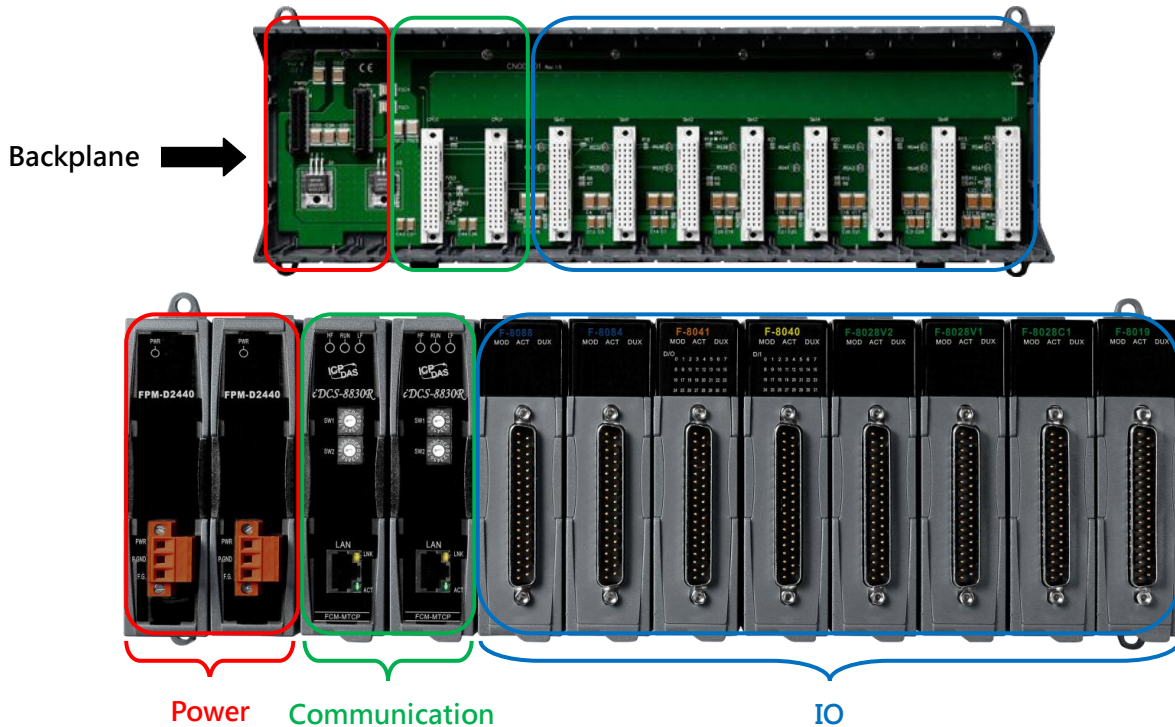

- **Backplane**

The backplane consists of 2 slots of power, 2 slots of communication and 8 single or 4 pairs of redundant I/O modules.

- **Power Module**

It provides the power to the system. It also bypasses 24V_{DC} to the I/O module to support passive loop. This module has hot-swappable and redundant functions.

- **Communication Module**

This module is a configurable communication interface that performs operation such as signal processing, automatically re-configuration, HART pass-through and configuration of I/O modules. The module connects to the controller or PLC through of the most popular industrial fieldbuses.

- **I/O Module**

The iDCS-8000 I/O modules can be inserted and removed from backplane without disturbing system operation.

- **Termination Board**

The termination boards provide the connection to the field. It also reduces the wiring and installation effort.

1.4 Hardware List

The equipment that is used as part of the iDCS-8000 station is presented in the following table.

Type		Module Name	Description
Communication Module		FCM-MTCP	Modbus/TCP Communication Module
Power Module		FPM-D2440	24VDC Input · 35W@5VDC Output
Digital I/O	Digital Input	F-8040	32 digital input channels, current sinking / sourcing, one common for 32 channels
	Digital Output	F-8041	32 digital output channel, current sinking, open collector
Analog I/O	Analog Input	F-8015	8 analog input channels, 3-wire RTD, Pt100, Pt1000
		F-8017C1	8 differential analog input channels, 4~20mA, with loop power for passive loop
		F-8017C2	16 differential analog input channels, 4~20mA
		F-8017CH	8 differential analog input channels, 4~20mA, HART interface, with loop power for passive loop
		F-8019	8 analog input channels, Thermocouple, mV, $\pm 5V$, $\pm 10V$
	Analog Output	F-8028CV	8 analog output channels, 4~20mA, $\pm 5V$, $\pm 10V$
		F-8028CH	8 analog output channels, 4~20mA, HART interface
Termination Board		DN-DIO-M	Termination board for digital I/O modules
		DN-DI-32DW	Termination board for digital input modules
		DN-DO-16DR-A	Termination board for digital output with power relay for channel 0~15
		DN-DO-16DR-B	Termination board for digital output with power relay for channel 16~31
		DN-AIO-M	Termination board for analog I/O modules
		DN-AIH-04	Termination board for HART analog input module
		DN-RTD-M	Termination board for RTD I/O modules
		DN-TC-M	Termination board for Thermocouple I/O modules
Accessories		4SIPP-801W-CAG	Dummy I/O cover
		FRMK	19" mounting panel
		CA-01	D-Sub 37pin Female-Male 1m Cable · 24AWG · 180° UL-2464
		CA-02	D-Sub 37pin Female-Male 2m Cable · 24AWG · 180° UL-2464
		CA-03	D-Sub 37pin Female-Male 3m Cable · 24AWG · 180° UL-2464
		CA-05	D-Sub 37pin Female-Male 5m Cable · 24AWG · 180° UL-2464
		CA-10	D-Sub 37pin Female-Male 10mCable · 24AWG · 180° UL-2464

1.5 Installation

1.5.1 Environment Specification

The following table is the absolute maximum rating of the environmental specification for the iDCS-8000.

Parameter	Specification
Operating Temperature	-25°C~75°C
Operating Humidity	5 ~ 95 % RH, non-condensing
Storage Temperature	-40°C~85°C
Storage Humidity	5 ~ 95 % RH, non-condensing
Operating Voltage	24V _{DC}
Maximum Operating Voltage	24V _{DC} + 10%

1.5.2 Dimensions

1.5.2.1 Module

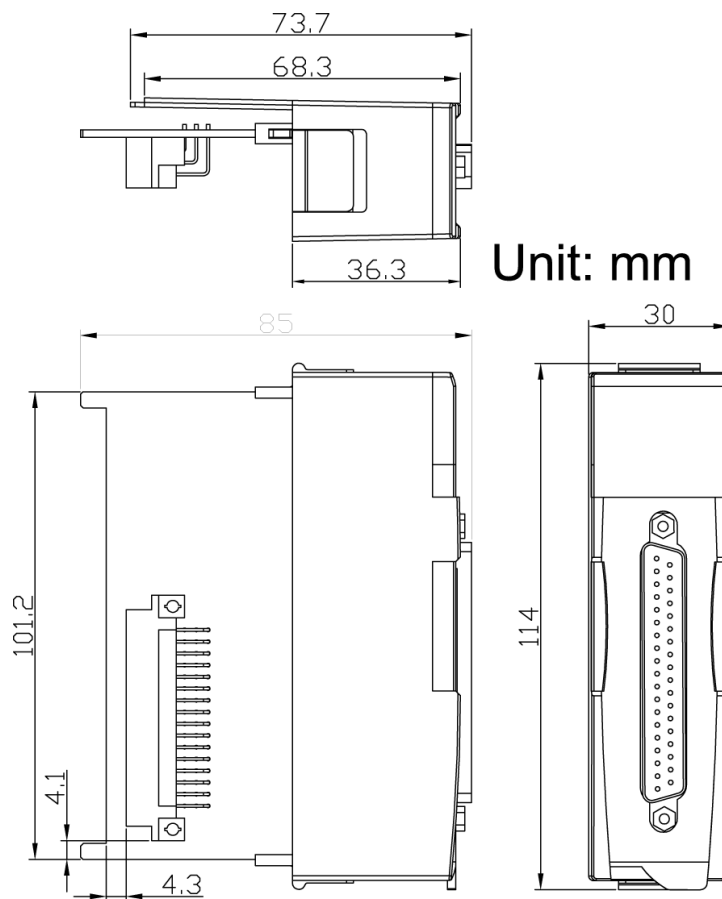

1.5.2.2 iDCS-8000 Body (Module Plugged)

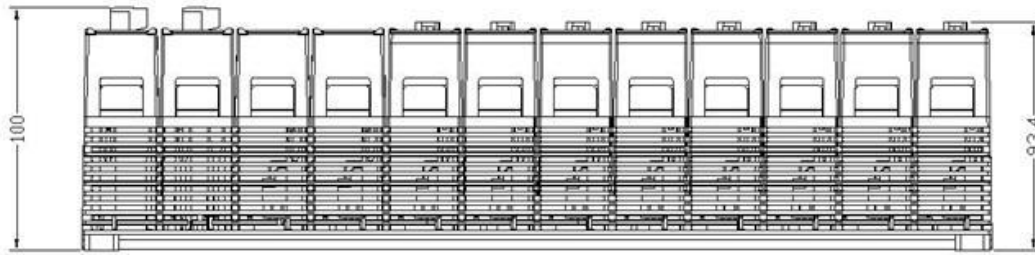

Top View

Units: mm

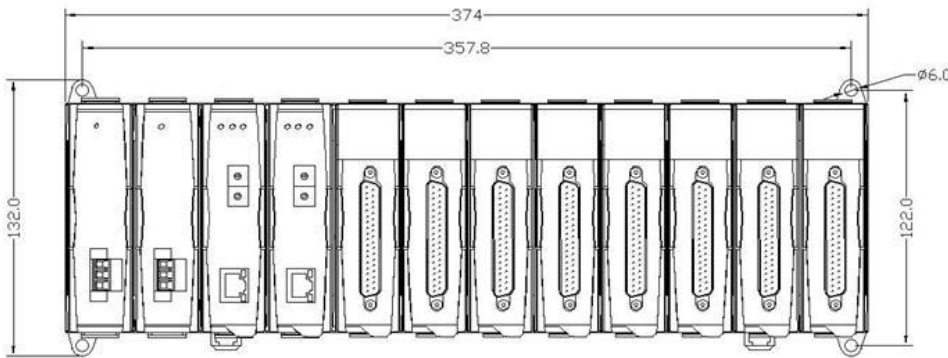

Front View

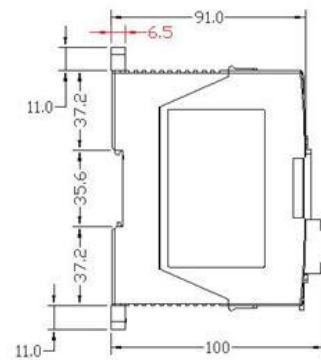

Left Side View

1.5.2.3 FRMK (Wall mount panel)

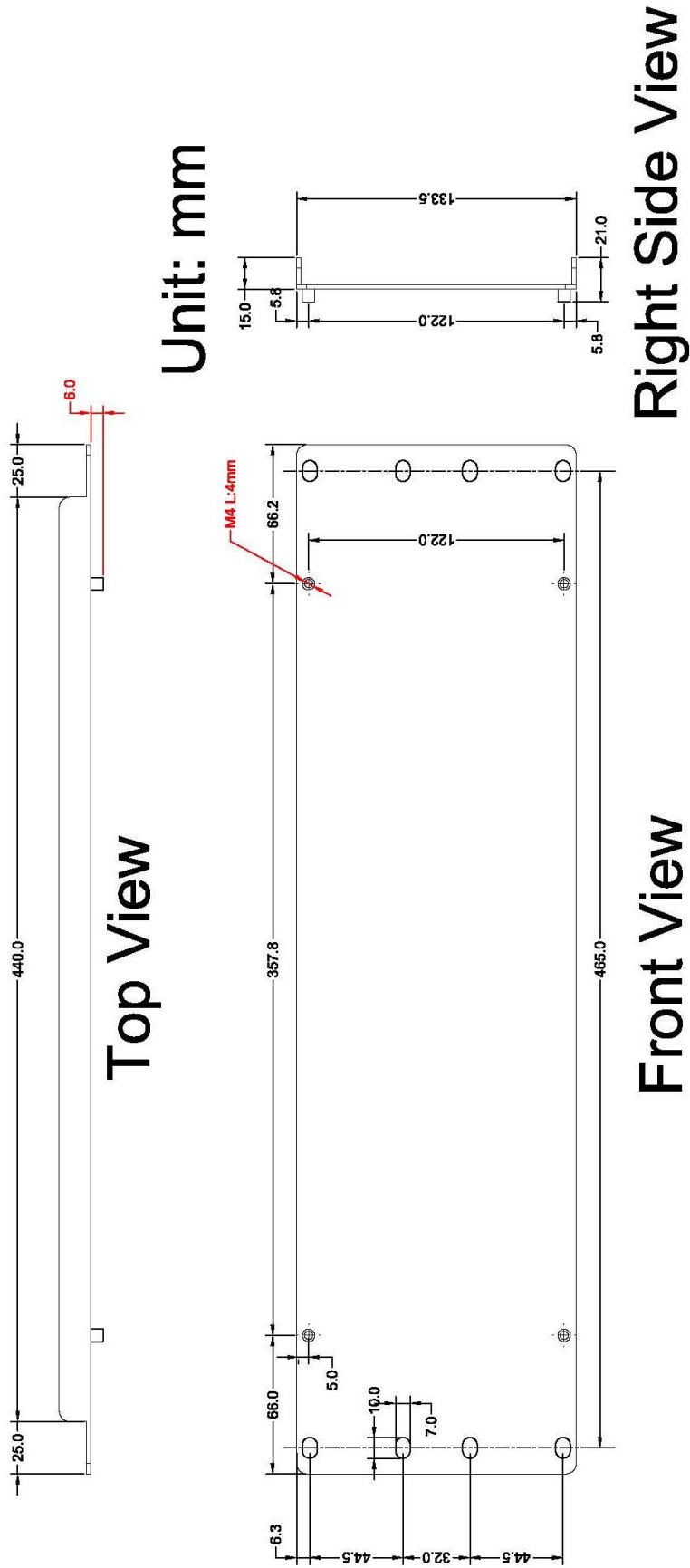

1.5.2.4 Termination Board

- DN-DO-16DR-A / DN-DO-16DR-B / DN-DI-32DW

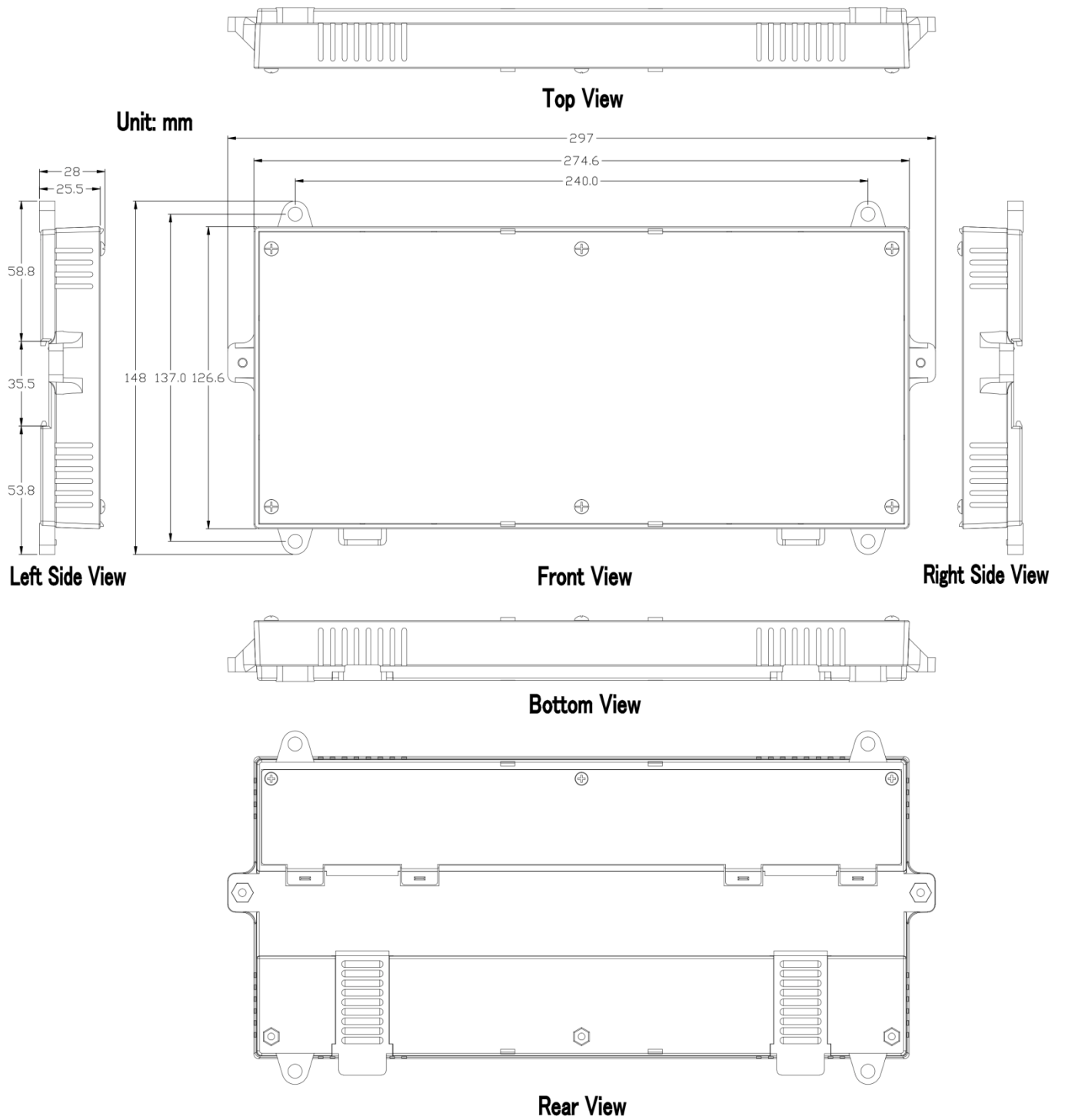

- DN-DIO-M / DN-AIO-M / DN-TC-M / DN-RTD-M

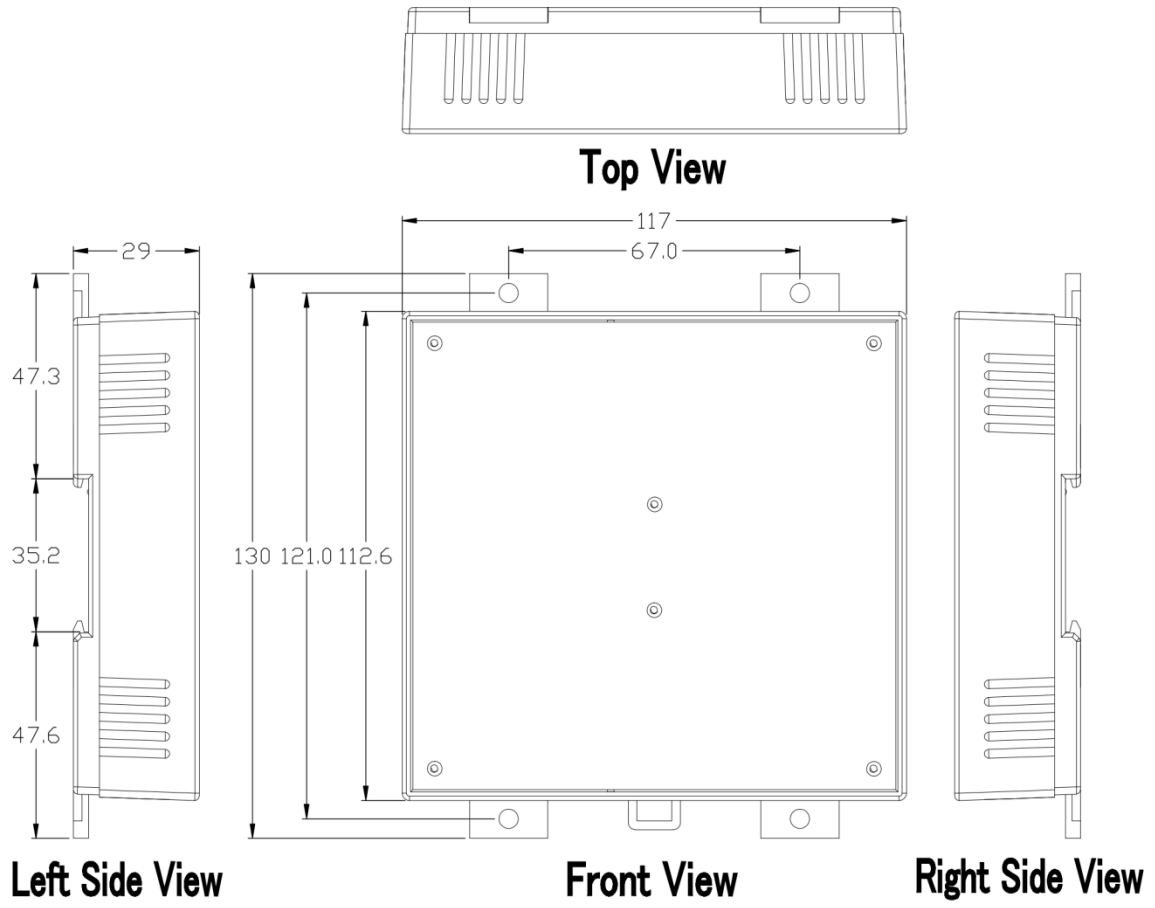

Unit: mm



Bottom View

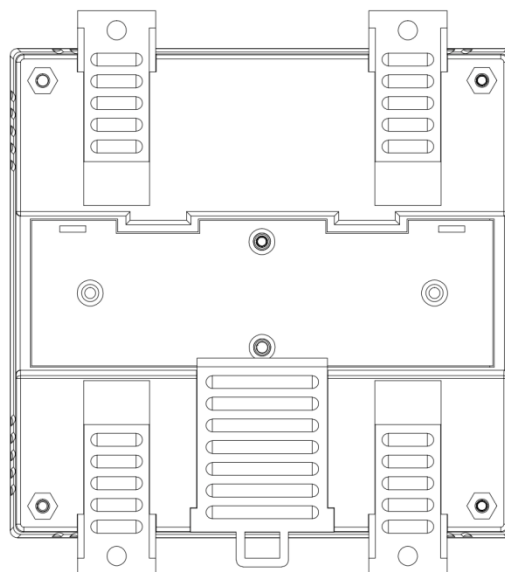

Rear View

● DN-AIH-04

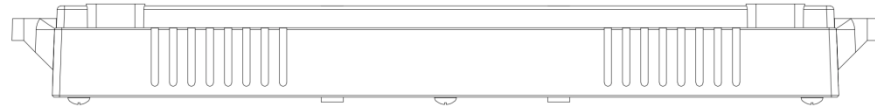

Top View

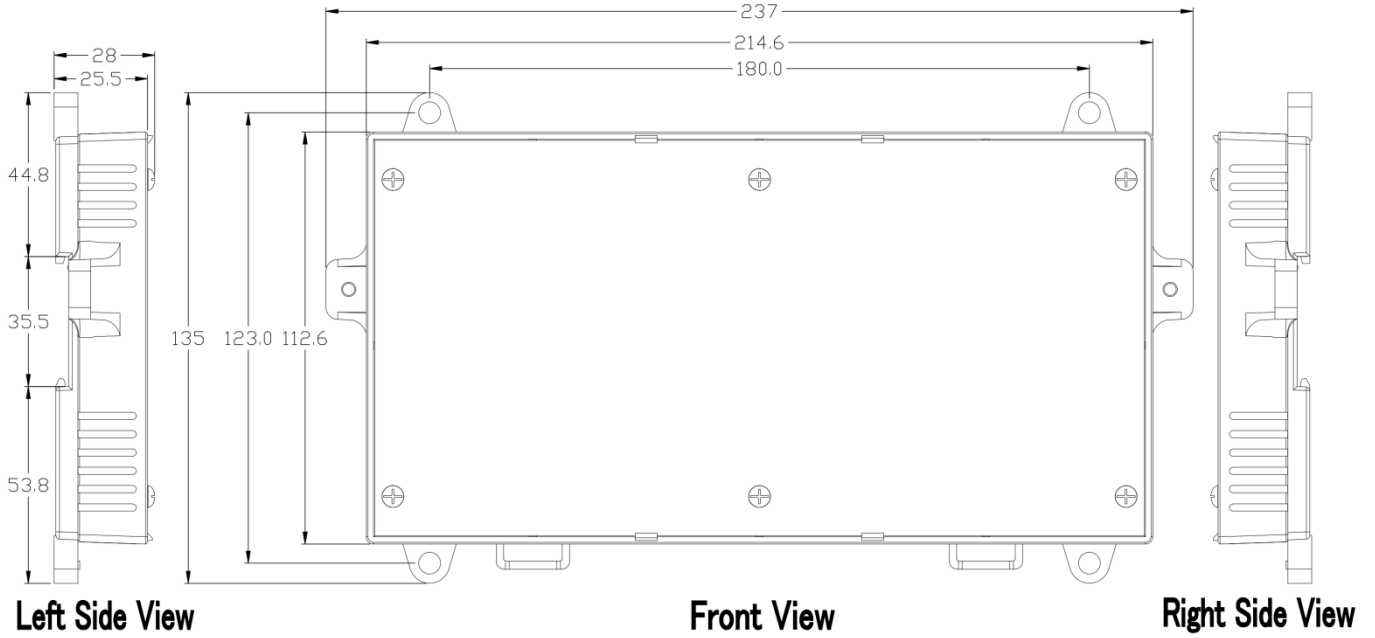

Left Side View

Front View

Right Side View



Bottom View

Unit: mm

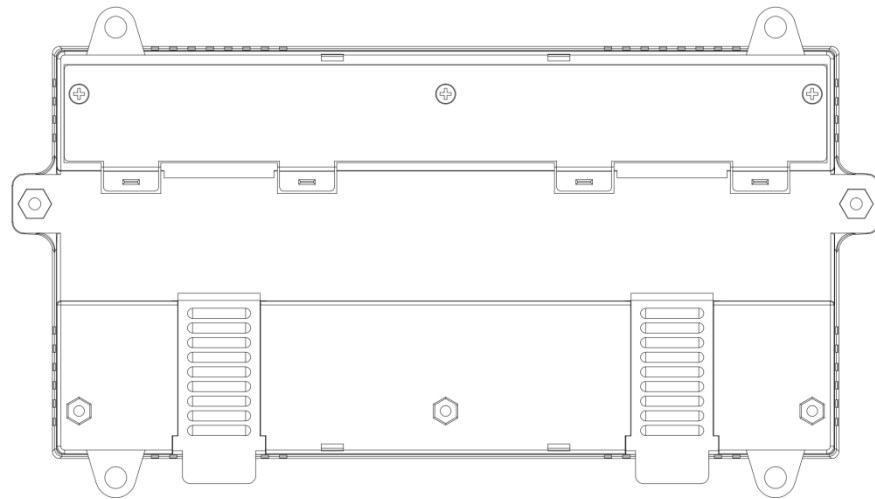

Rear View

1.5.3 Mounting

There are 3 types of mounting, the DIN-rail, panel and wall, for iDCS-8000 to install in your cabinet or other places. The iDCS-8000 is originally designed for DIN-rail and wall mounting by the mechanism. The following section will describe how to mount the iDCS-8000 in different type.

1.5.3.1 DIN-rail mounting

- Use screw drive to mount the DIN-rail with M4 screw

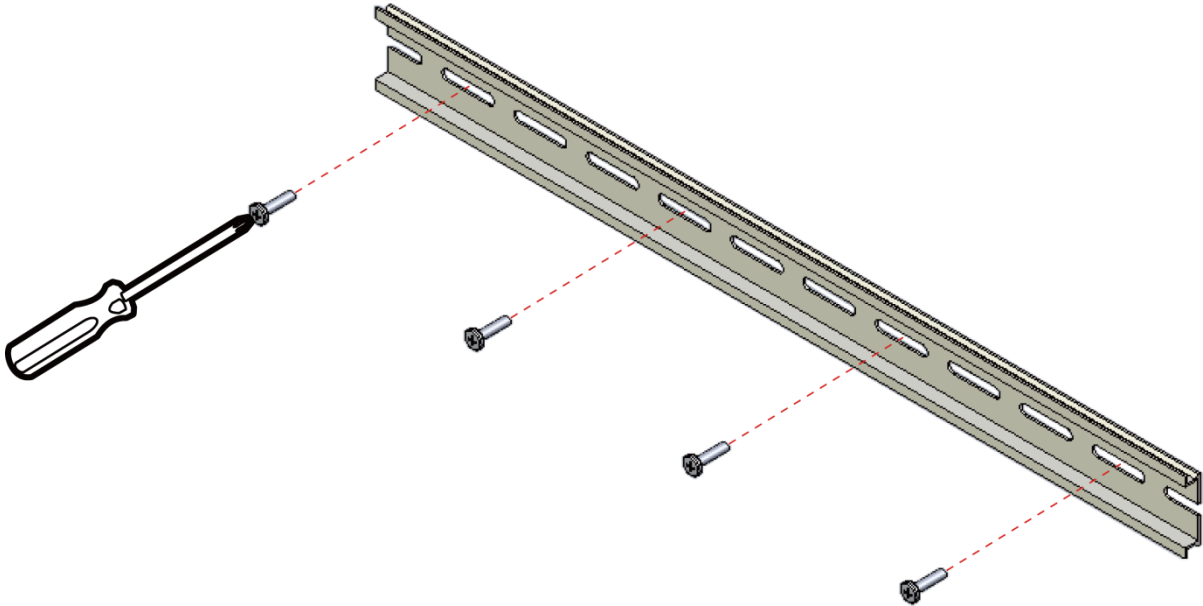

- Mounting the iDCS-8000 unit to the DIN-rail

1. Pull down the DIN-rail lock behind the iDCS-8000 unit
2. Attach the iDCS-8000 unit on the DIN-rail
3. Slide the DIN-rail lock up to fix iDCS-8000 to the DIN-rail

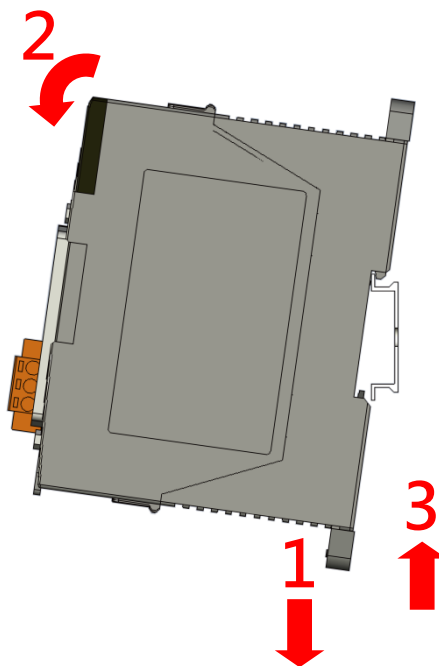

- Successful mounting iDCS-8000

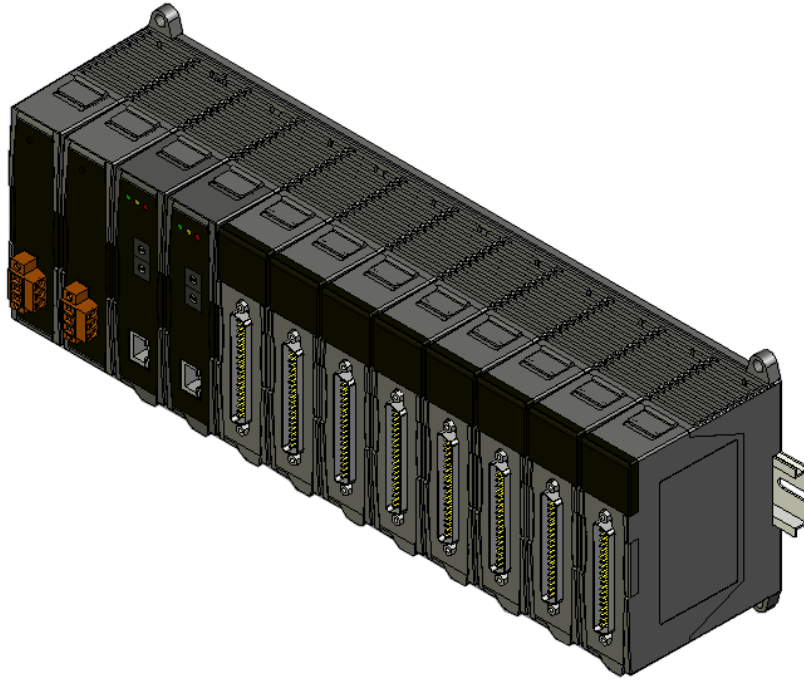

1.5.3.2 Panel mounting

- Use screw drive to mount the iDCS-8000 to the FRMK with M4 screw

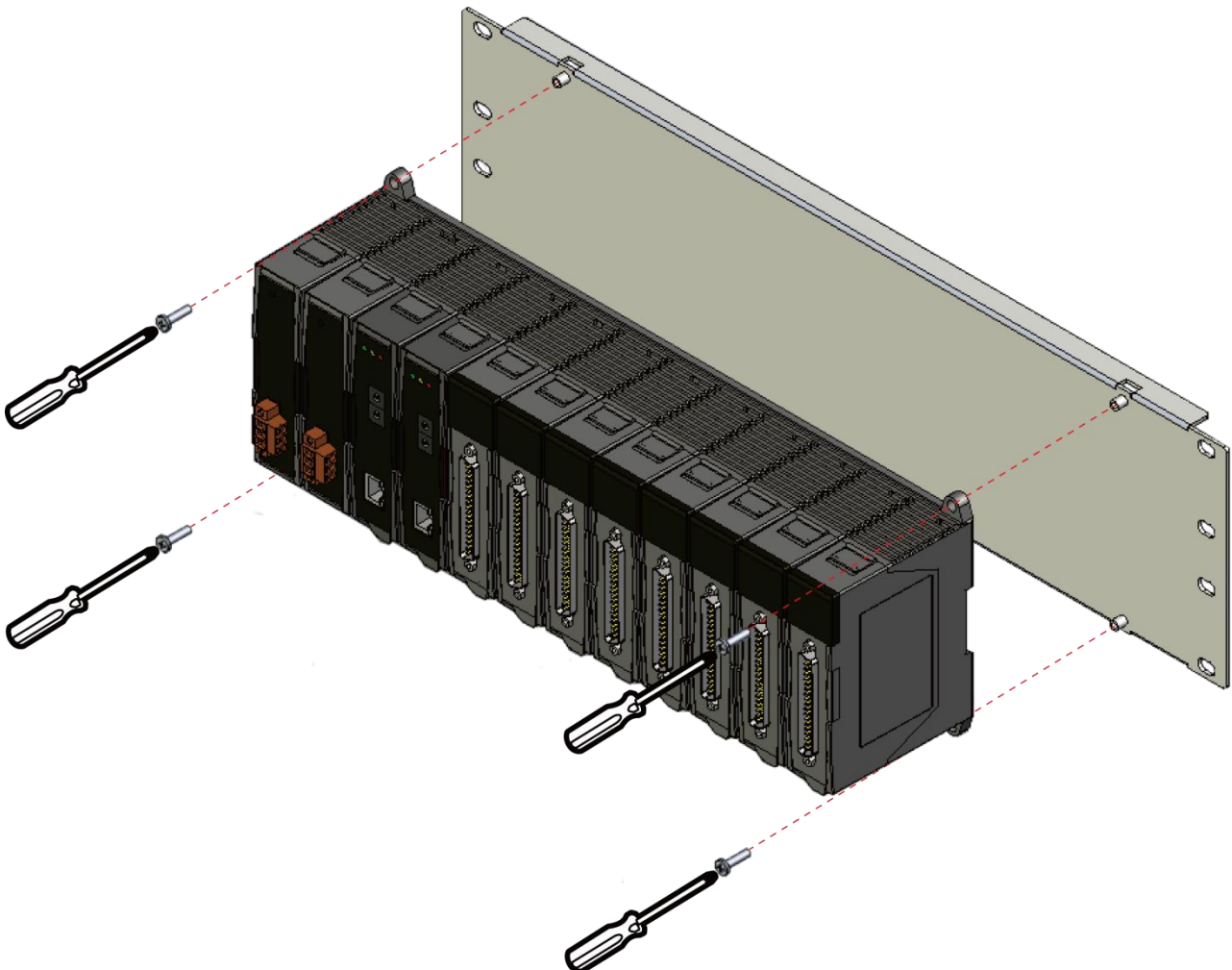

- Then mount the FRMK panel

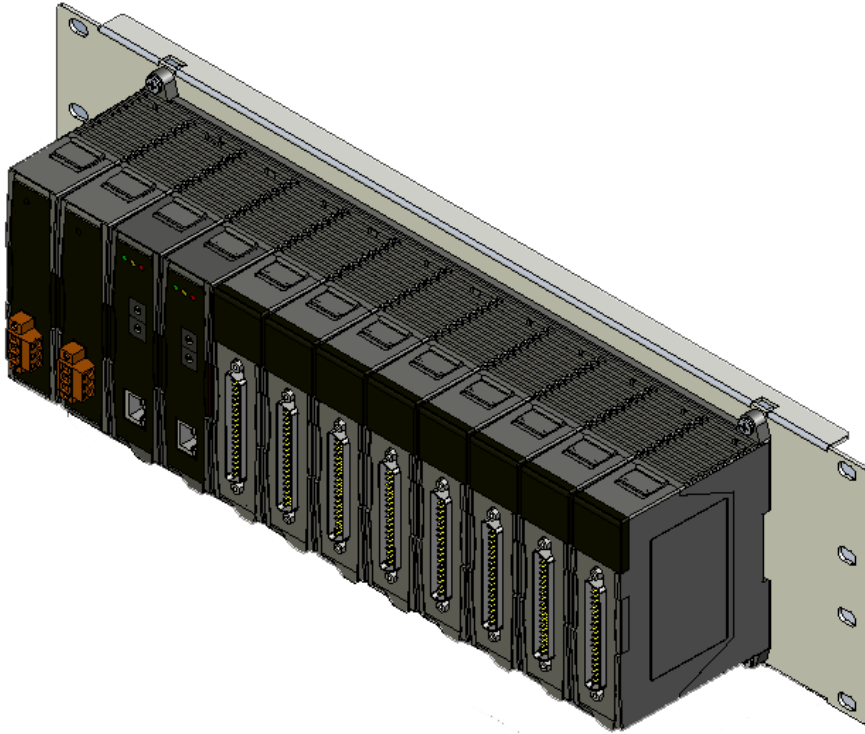

1.5.3.3 Wall mounting

The steps of wall mounting are same as panel mounting. The difference between panel and wall mounting is the FRMK unit. The 4 M4 screws directly screwed iDCS-8000 unit to the plane you want.

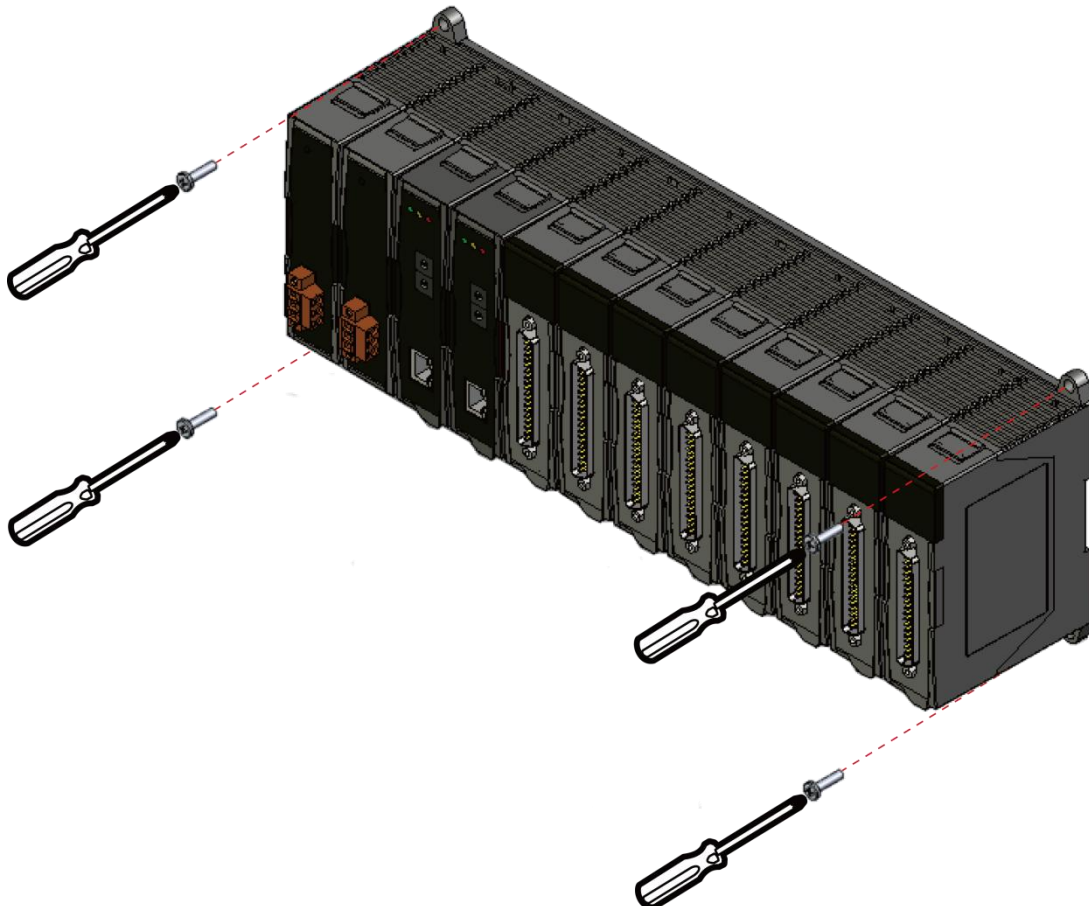

1.5.4 Module Installation

- Installing along the guiding rail then pushing into 48-pin socket

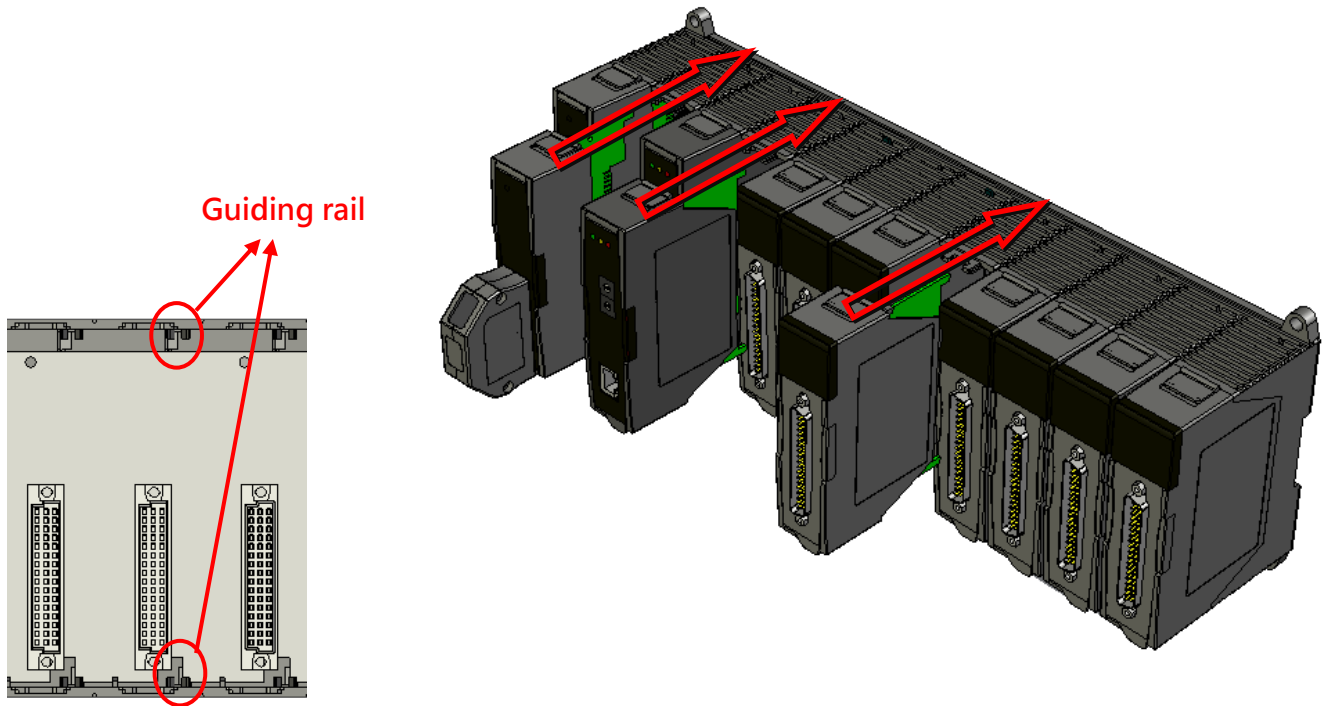

- Lock the module

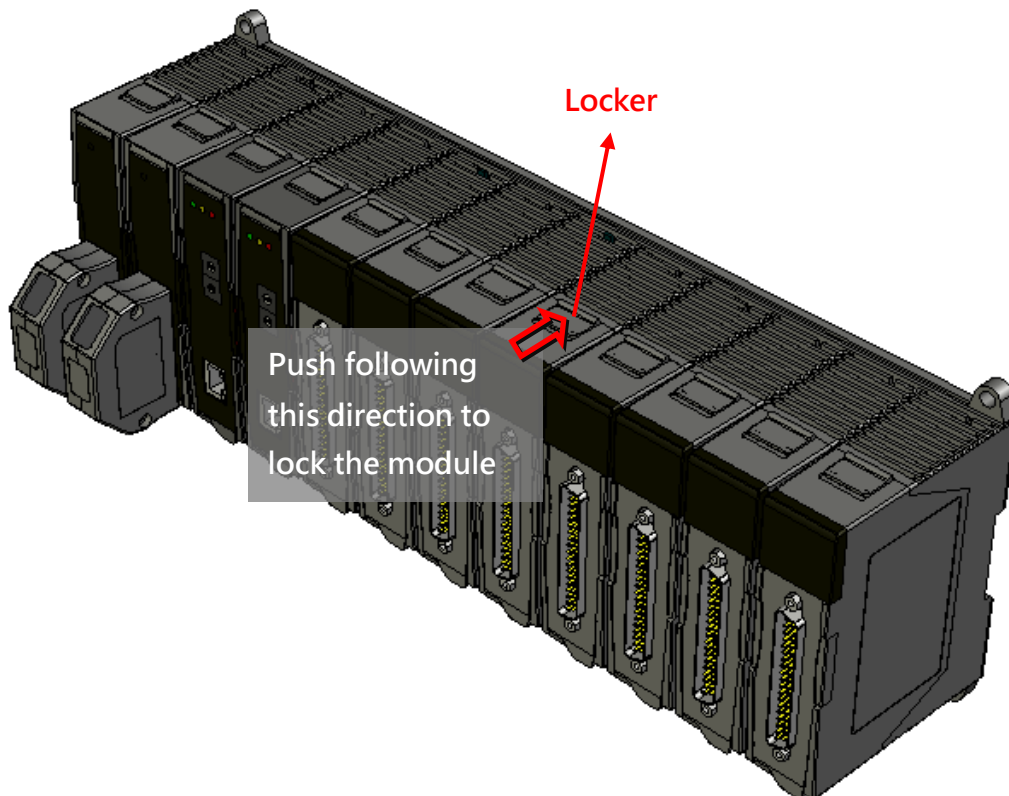

1.5.5 Wiring

- Single Operation



- Redundant Operation

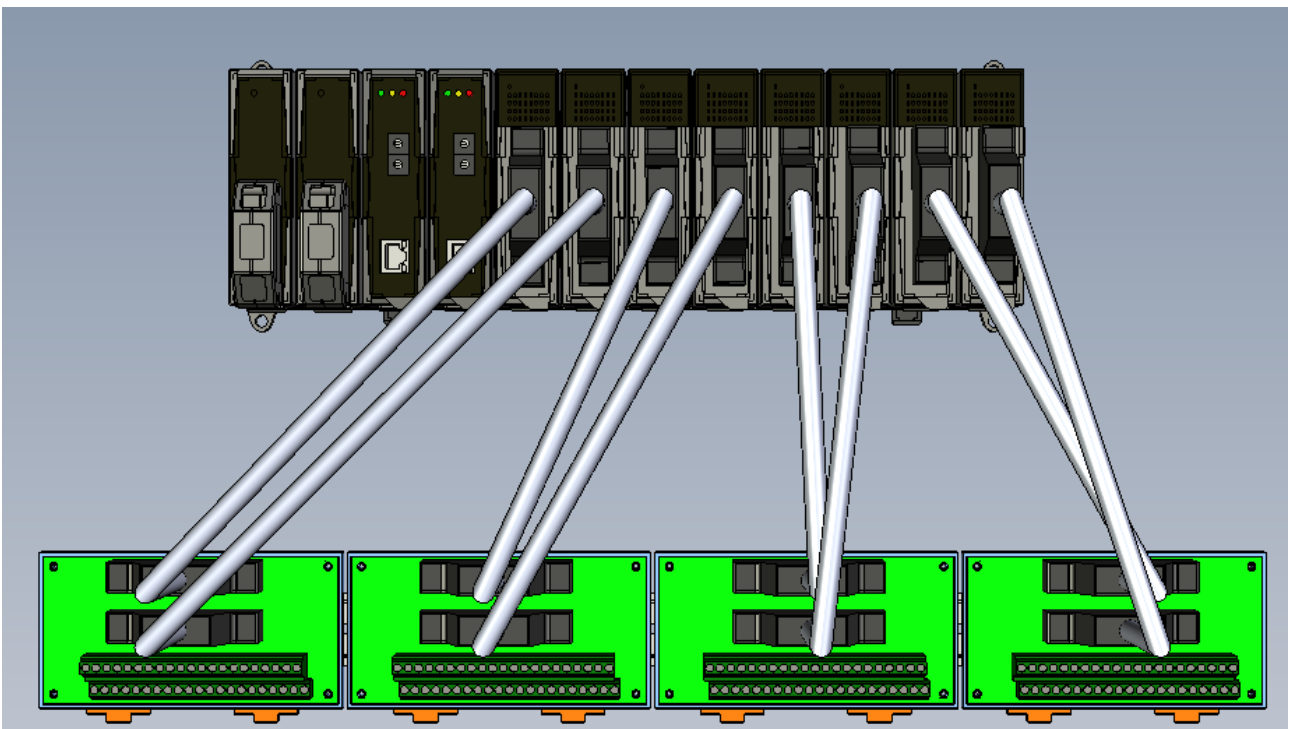

1.5.6 Field Grounding

The hardware circuit is easily broken by the noise, ESD (Electrostatic Discharge), EFT (Electrical Fast Transient), and surge, in the field. The iDCS-8000 provides a frame ground to gain noise immunity. This can prevent the damage caused by noise and increase the system stability.

There are many ways to ground iDCS-8000 to earth ground. The most common way to ground to earth is by using the sheet metal behind the iDCS-8000. When mount the iDCS-8000 with DIN-rail in cabinet, the sheet metal will attach to the conductor of the cabinet to lead to ground.

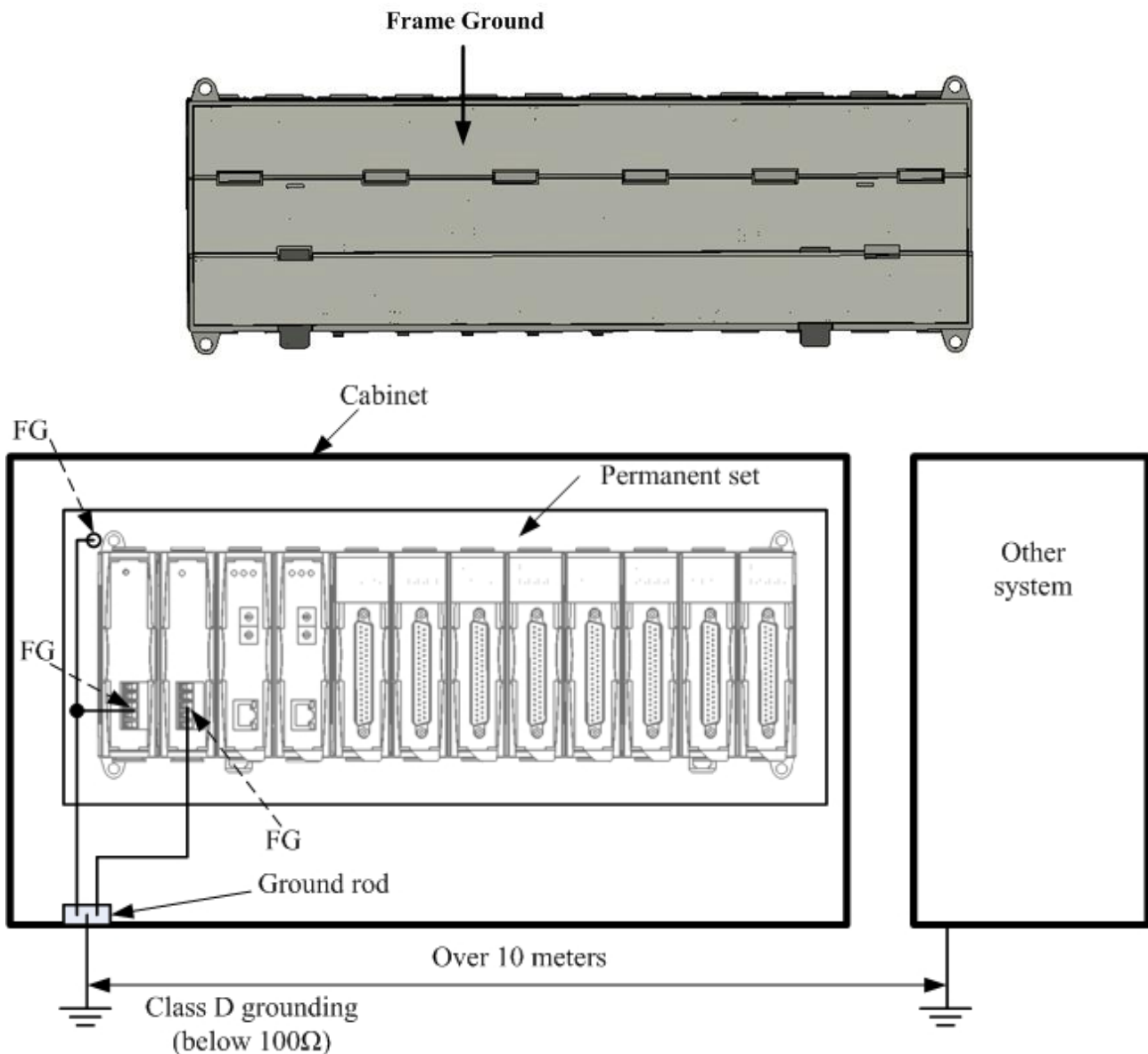

1.5.6.1 Grounding

In order to prevent the operators to get an electric shock and external noise to affect iDCS-8000 system, the cabinet of the iDCS-8000 must set earthed. And all the metal that the operators might touch must set earthed. The grounded system must follow “Electrical Equipment Technical Standard” Class D specification and the earth resistance must be below 100Ω . (Note: There is a 3 kVDC high-tension condenser between the S.G and F.G of iDCS-8000).

The grounded system of the iDCS-8000 must follow Class D specification. When grounding, please do not share the ground point of the iDCS-8000 with other power system. And the distance between two ground points must greater than 10 meters.

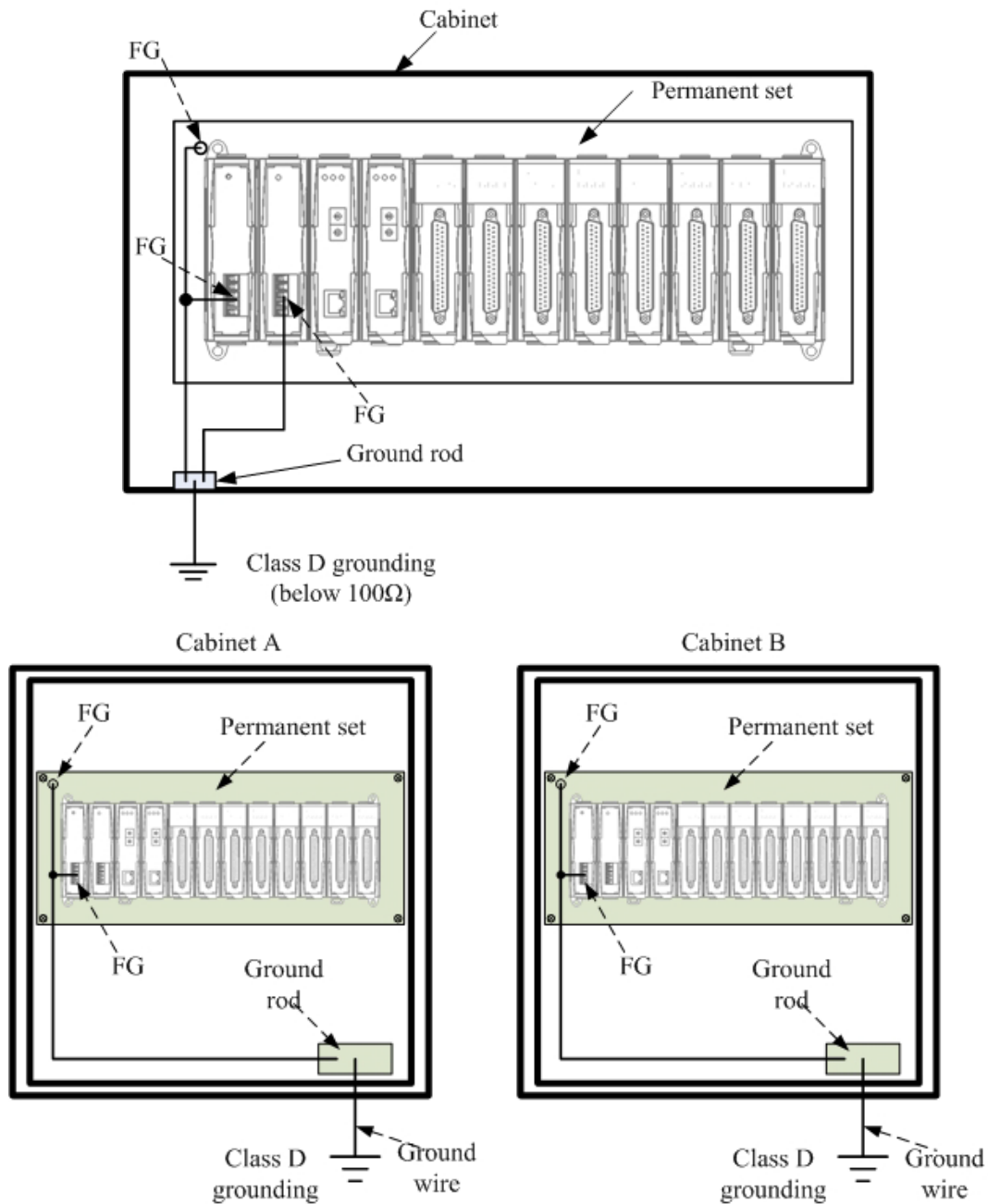

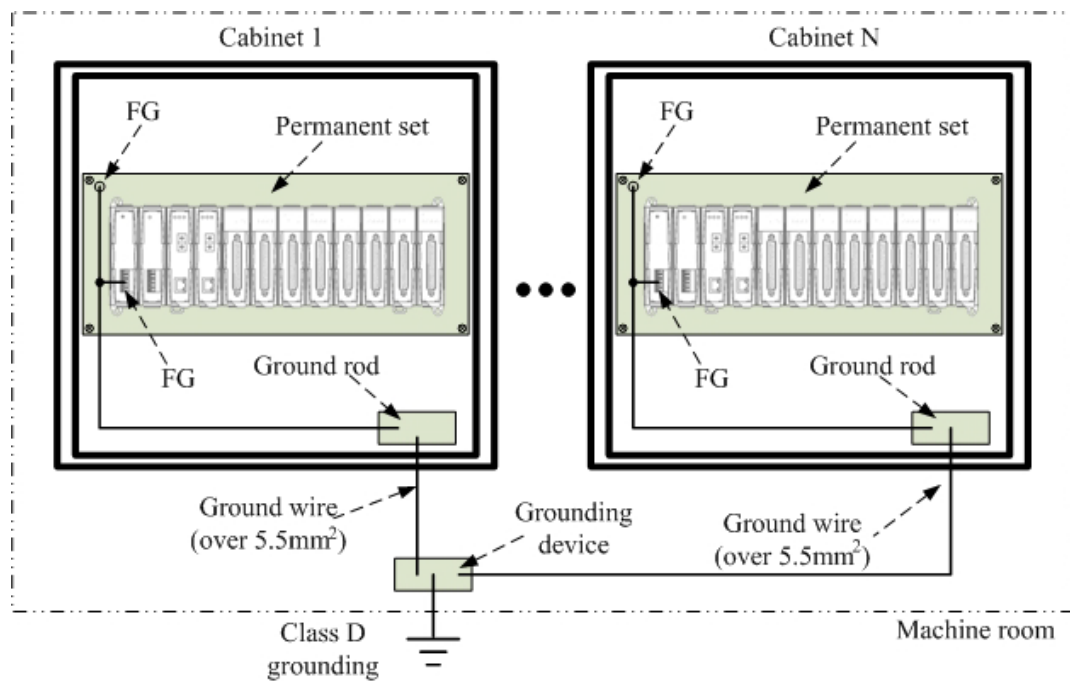
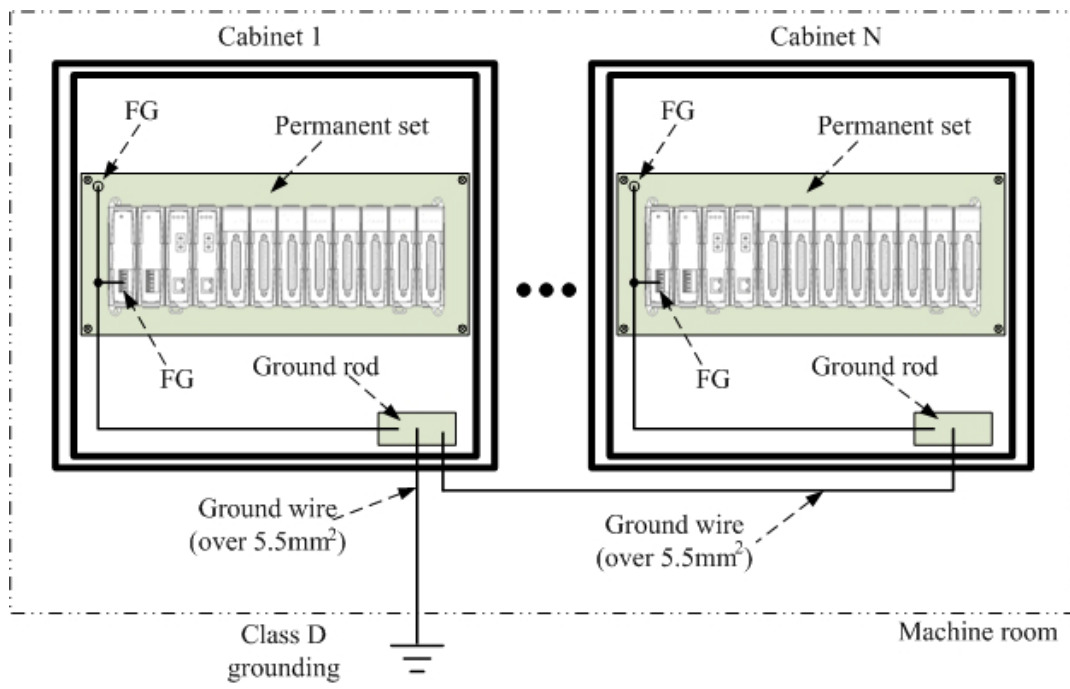

1.5.7 Terminals and Wiring

The termination board of the iDCS-8000 is a bridge between field devices and I/O modules. The termination board provides a pluggable terminal block to connect field devices to termination board. Users can easily replace the termination board by removing the pluggable terminal block.

1.5.7.1 Pluggable Terminal Blocks

- Specification

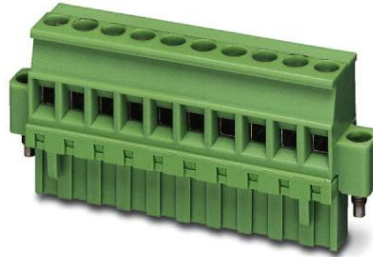

Parameters	Value
Tightening Torque	0.6 Nm / 5.31048 Lb.in
Wire Size	12~24 AWG
Insulating Material	PA
Inflammability Class	UL 94 V0
Nominal Current	12 A
Nominal Voltage	250 V
Contact	Tin plated
Screw Thread	M3
Operating Temperature	-40°C to +105°C

- Dimension (Unit: mm)

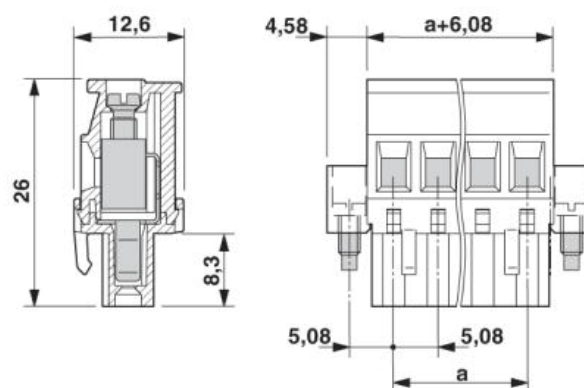

1.5.7.2 Wiring

The following table is the recommended wire and end-cord terminals.

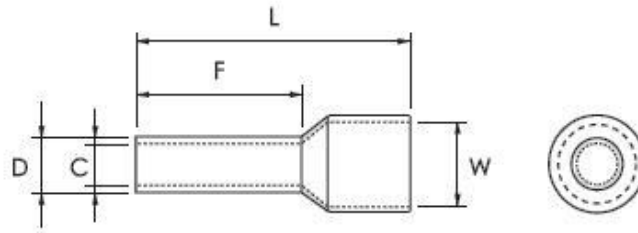

Wire AWG	Recommended conductor (mm)	Deiension (mm)			
		L	F	C	W
20	0.5	16	10	1	2.6
18	0.75	18	12	1.2	2.8

1.5.8 Cable

There are three cables with different length can be used to connect the I/O module and the termination board.

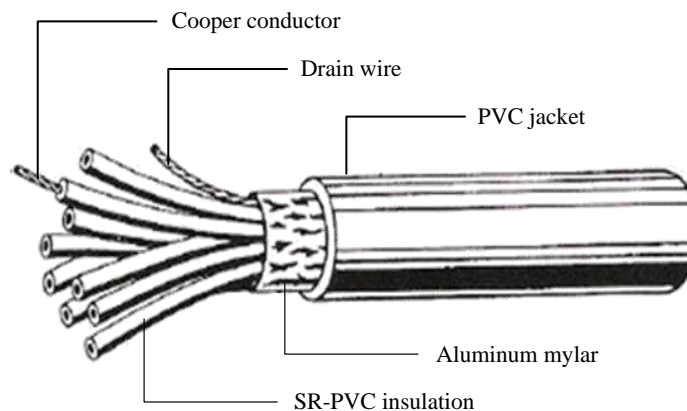

Model	Length	Material	Rated Temp.	Connector Type
CA-01	1m	Semi-rigidPVC	80°C	37P D-Sub Male Cable
CA-02	2m	Semi-rigidPVC	80°C	37P D-Sub Male Cable
CA-03	3m	Semi-rigidPVC	80°C	37P D-Sub Male Cable
CA-05	5m	Semi-rigidPVC	80°C	37P D-Sub Male Cable
CA-10	10m	Semi-rigidPVC	80°C	37P D-Sub Male Cable

Section 2 Power Modules

2.1 FPM-D2440

2.1.1 Overview



- 24VDC input
- Diagnostic
- Redundancy

The FPM-D2440 is a power module. It offers the isolated power source to the iDCS-8000 system. The FPM-D2440 can be used to single or redundant application. It also has diagnostic to make system more reliable.

2.1.2 Specification

Parameter	Value
Voltage input	24V _{DC} ±20%
Voltage output	5 V _{DC} ±2% 24V _{DC} (Depending on input power source)
Current output	5V _{DC} : 7.5A max 24V _{DC} : 5A max
Insulation resistance	1000MΩ
Isolation	1500V _{DC} min
Short circuit protection	Yes (Continuous)
Redundancy	Yes
Operating temperature	-25°C ~ +75°C
Dimension	31mm x 91mm x 115mm (W x L x H)
Conducted emission	EN55022 Class A
Radiated emission	EN55022 Class A

2.1.3 Pin Assignment

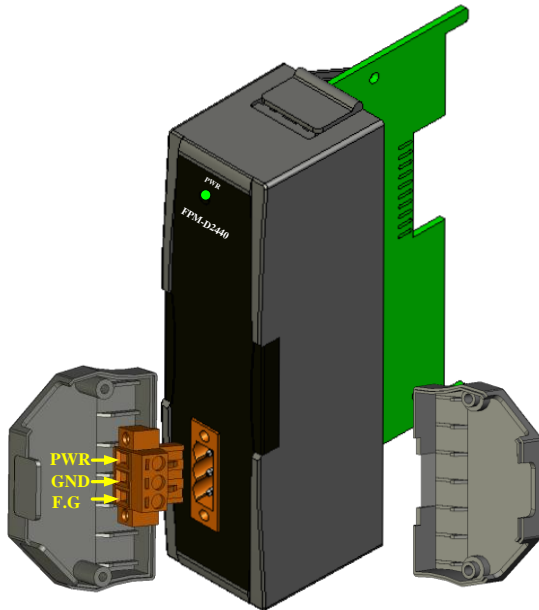

Pin	Description
PWR	24 VDC
P.GND	Ground
F.G	Frame Ground

2.1.4 LED Indicator



LED	Status	Description
PWR	On	Normal operation
	Off	<ul style="list-style-type: none"> ● No input or invalid input ● Output lower than 4.5V_{DC} ● Module failure ● Output overloaded

2.1.5 Internal Hardware Structure

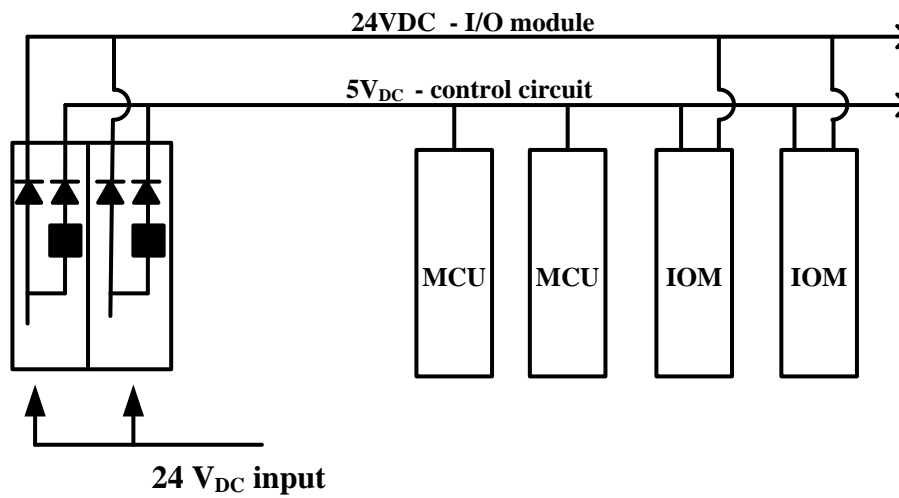

2.1.6 List of Power Consumption of Module

Model Name	Maximum Output Current
F-8040	1.8 W
F-8041	2.3 W
F-8017C1	1.5 W
F-8017C2	2.2 W
F-8017CH	1.2 W + 7.5W ¹
F-8028CV	0.5W + 11 W ²
F-8028CH	0.5 W + 10 W ²
F-8015	1 W
F-8019	1.3 W
F-8084	1.3 W + 1.1 W

1. 24V is used for the power in passive loop. The power consumption depends on the number of sensors are connected.
2. The power consumption depends on the load.

Section 3 Communication Module

3.1 FCM-MTCP

3.1.1 Overview



- Modbus/TCP
- Hardware selectable node ID
- Redundancy
- LED indicators for local diagnostic

The FCM-MTCP is a communication module with Modbus/TCP through ethernet port. The Modbus/TCP is a standard protocol commonly used in industrial applications. The FCM-MTCP can be used for the Modbus/TCP client to access I/O modules. It is built-in two rotary switches to easily configure node ID without utility. There are also 3 LED indicators for system diagnostic and 2 LED indicators for network status, users can locally check system and network status. The FCM-MTCP not only offers single operation but also redundant, this benefit brings I/O system more reliable.

3.1.2 Specification

Parameter	Value
LAN Port	10/100BASE-TX (Auto negotiating, Auto MDIX)
Protocol	Modbus/TCP
LED indicators	1 Power, 2 Fault, 1 Link/Active/Speed
Power consumption	2 W
Redundant	Yes
Operating temperature	-25°C ~ +75°C
Isolation	3000V _{DC} (Between LAN port and F.G) 1000V _{DC} (Between LAN port and backplane)

3.1.3 Switches

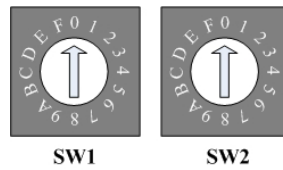

The switches are used for the value of the 4th IP address. The valid number of the address is from 1 to 254. The other 3 addresses can be configured through MiniOS7 Utility.

3.1.4 LED Indicators

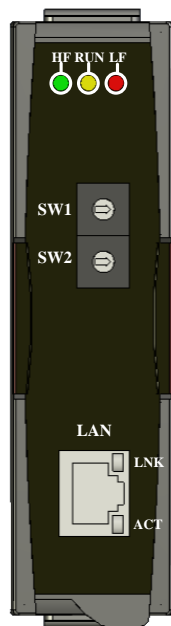

LED	Status
HF	On : Heavy fault Off : Normal
RUN	On : Module Power On Off : Module Power Off
LF	On : Light fault Off : Normal
LNK	On : Ethernet Link Establish Off : No Ethernet Link
ACT	On : Ethernet Activity Off : No Ethernet Activity

3.1.5 Ethernet Port

The iDCS-8000 is equipped with one Ethernet port which is fully compliant with IEEE 802.3u 10/100BASE-TX. The Ethernet port provides a standard RJ-45 with green color LED indicator on the front side showing activity (Off: No activity, Green and Flash: Activity), and orange color LED indicator showing link status (Off: No Link, Orange: Link established).

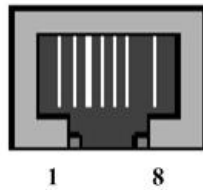

Pin	Name	Color	Description
1	TX+	Clear white	Transmit Data+
2	TX-	Clear	Transmit Data-
3	RX+	Green white	Receive Data+
4	N.C.	Blue	Not Connected
5	N.C.	Blue white	Not Connected
6	RX-	Green	Receive Data-
7	N.C.	Brown white	Not Connected
8	N.C.	Brown	Not Connected

Recommended Media

UTP/STP Cable

10Mbps : Category 3 or greater

100Mbps : Category 5 or greater

Section 4 I/O Module

4.1 Introduction

4.1.1 LED status

Each module has three LED indicators for diagnostic. These three indicators represent different situation when system is operating. The LED indicators can help users to identify failures of the module.

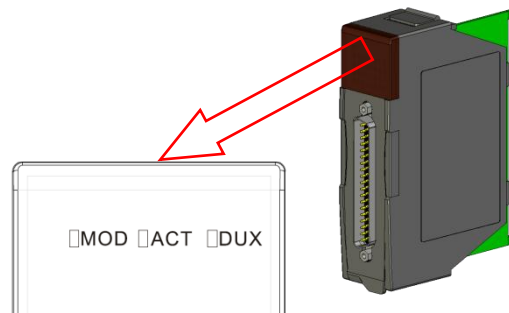

Status		Description	
MOD	Solid	Operating Mode	
	Blink	0.2 second period	Halt Mode (Caused by heavy fault)
		1 second period	Stop Mode (Caused by light fault)
ACT	Solid	Single	Output/Input Enable
		Redundant	Master & Output/Input Enable
	Off	Single	Output/Input Disable
		Redundant	Slave & Output/Input Disable
DUX	Solid	I/O Module is operating in redundant mode	
	Off	I/O Module is operating in single mode	
ALL	Blink	In the bootloader mode and preparing upgrade firmware	
IO*	Solid	The corresponding I/O channel is activated	
	Off	The corresponding I/O channel is inactivated	

* Not all of I/O modules have IO LED indicators.

4.1.2 D-Sub 37 pin connector

The D-Sub 37 pin connector is the interface to field devices. Every module has individual pin assignment for wiring. The termination boards are wiring boards used for easily wiring and maintenance purpose.

4.1.3 Timing Characteristics

Parameter	Value	Description
T ₁	800 ms	Hardware watchdog activated
T ₂	50 ms	I/O modules lose connection to the termination board
T ₃	<1 ms	Response time for analog output high/low alarm
T ₄	<16 ms (8 channels)	Response time for analog input high/low alarm
	<32 ms (16 channels)	
T ₅	<1.2 s	Response time for TC/RTD high/low alarm
T ₆	<100 ms	Time when detect CJC broken
T ₇	<1.2 s	Time when detect TC/RTD channel broken

4.2 Digital Input

4.2.1 F-8040

4.2.1.1 Overview



- 32 digital input (sink/source) channels
- Digital filter (1~32767ms)
- Input channel LED indication
- RoHS compliance
- 3000 V_{DC} isolation from input to backplane
- 3000 V_{DC} isolation from input to frame ground
- Redundancy
- Fast redundant switching time (<100us)

The F-8040 features 32 digital input (sink/source) channels. Either sink- or source-type input can be selected via different wiring. The F-8040 can determine binary input from a DC voltage source. The digital input channels also offer LED indicators to locally display digital input status. Moreover, the module offers 3000 V_{DC} optical isolation between channels and backplane bus. If any high voltage or current damages the channels, the system (backplanes, other modules, and control unit) won't be affected because of the benefits of isolation.

4.2.1.2 Specification

Parameter	Value
Feature	
Redundant	Yes (Switching time < 100us)
Termination board break off detection	Yes
Digital filter	Yes (1ms~32767ms)
LED indicator	1 RUN, 1 ACT, 1 DUX
	32 as channel 0~31 status
Digital Input	
Channels	32 (One COM for all channels)
Type	Wet, current sinking / sourcing
Rated voltage	36 V _{DC}
Input voltage range, "1"	18 V _{DC} ~30 V _{DC}
Input voltage range, "0"	11 V _{DC}
Detection time	100us
Input impedance	5.2KΩ, 0.25W

Nominal input channel current	4.85mA @ 24V _{DC}
Maximum input current	7mA @ 24V _{DC}
Field-to-Logic isolation	3000V _{DC}
Certification	
EMC	EN61000-6-2, EN61000-6-4 IEC/EN 61000-4-2, IEC/EN 61000-4-4
General	
Termination board	DN-DI-32DW, DN-DIO-M
Maximum power consumption	1.8 W
Operating temperature	-25°C ~ +75°C
Humidity	5 ~ 95 % RH, Non-condensing
Weight	300 g
Dimensions (W x L x H)	30mm x 85mm x 115mm

4.2.1.3 Hardware Structure

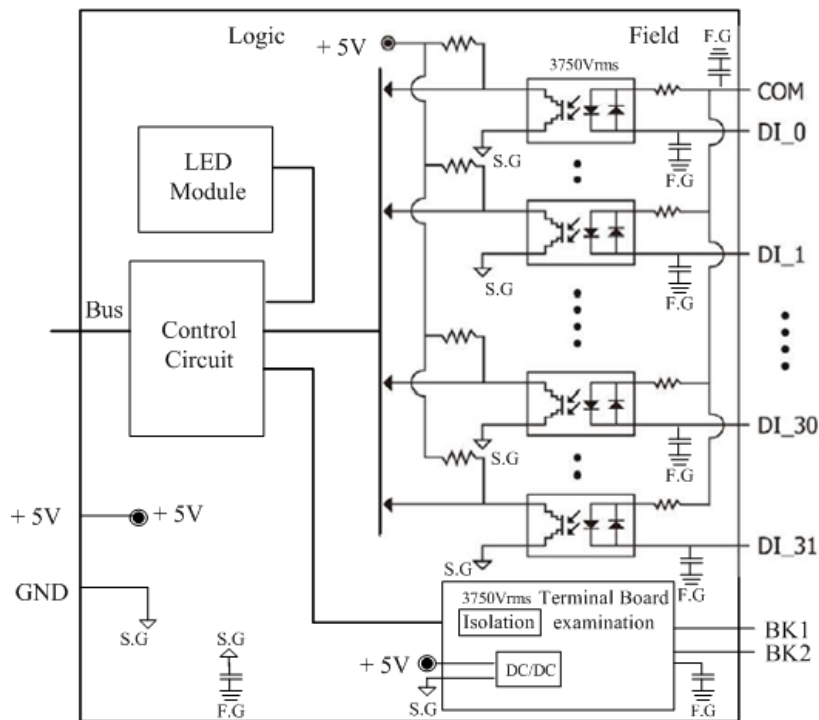

4.2.1.4 Pin Assignment

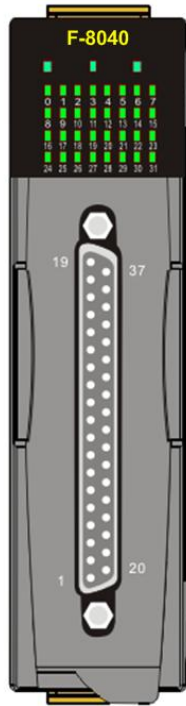

Pin Assignment Name	Terminal No.	Pin Assignment Name
DI.COM	19	
X	18	BK2
DI_15	17	X
DI_14	16	DI_31
DI_13	15	DI_30
DI_12	14	DI_29
DI_11	13	DI_28
DI_10	12	DI_27
DI_9	11	DI_26
DI_8	10	DI_25
DI_7	09	DI_24
DI_6	08	DI_23
DI_5	07	DI_22
DI_4	06	DI_21
DI_3	05	DI_20
DI_2	04	DI_19
DI_1	03	DI_18
DI_0	02	DI_17
BK1	01	DI_16

37-pin male D-Sub Connector

4.3 Digital Output

4.3.1 F-8041

4.3.1.1 Overview



- 32 digital output (sink) channels
- Safety value (Preset/Hold)
- Power-on(Initial) value
- Output channel LED indication
- RoHS compliance
- 3000 V_{DC} isolation from output to backplane
- 3000 V_{DC} isolation from output to frame ground
- Redundancy
- Fast redundant switching time (<100us)

The F-8041 is a digital output module with 32 NPN channels. The output channel of F-8041 is a current sinking channel and can drive the load up to 0.5A current. The digital output channels offer LED to indicate digital output status. Moreover, the module offers 3000 V_{DC} optical isolation between channels and backplane bus. If any high voltage or current damages the channels, the system (backplanes, other modules, and control unit) won't be affected because of the benefits of isolation.

4.3.1.2 Specification

Parameter	Value
Feature	
Redundant	Yes (Switching time < 100us)
Termination board break off detection	Yes
Safety output	Yes (Preset/Hold)
Power-on (Initial) output	Yes
LED indicator	1 RUN, 1 ACT, 1 DUX
	32 as channel 0~31 status
Digital Output	
Number of channels	32 (NPN)
Type	Current sinking, Open-collector
Rated voltage	36 V _{DC}
Output load current, maximum	0.5 A
Output switching time	100 us
Output impedance	2 Ω
Isolation	3000V _{DC}

Certification	
EMC	EN61000-6-2, EN61000-6-4 IEC/EN 61000-4-2, IEC/EN 61000-4-4
General	
Termination board	DN-DO-16DR-A, DN-DO-16DR-B, DN-DIO-M
Maximum power consumption	2.3 W
Operating temperature	-25°C ~ +75°C
Humidity	5 ~ 95 % RH, Non-condensing
Weight	300 g
Dimensions (W x L x H)	30mm x 85mm x 115mm

4.3.1.3 Hardware Structure

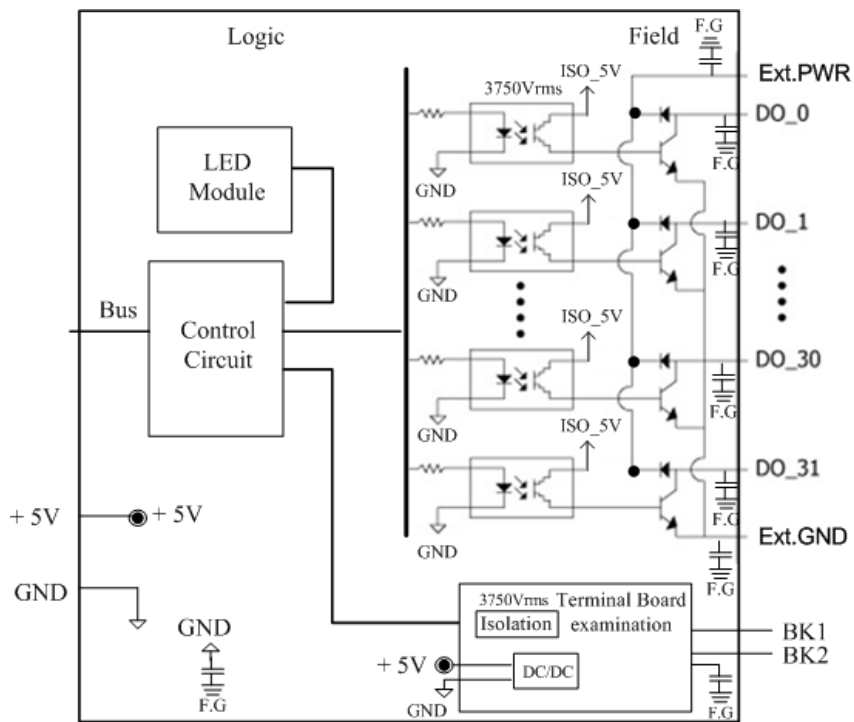

4.3.1.4 Pin assignments

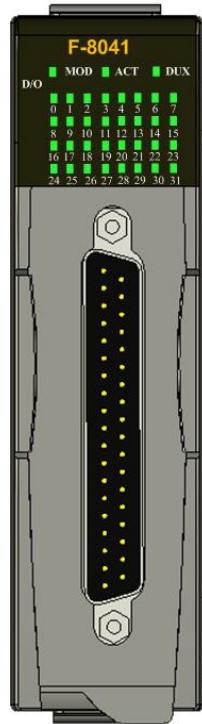

Pin Assignment Name	Terminal No.	Pin Assignment Name
Ext.PWR	19	BK2
Ext.GND	18	Ext.GND
DO_15	17	DO_31
DO_14	16	DO_30
DO_13	15	DO_29
DO_12	14	DO_28
DO_11	13	DO_27
DO_10	12	DO_26
DO_9	11	DO_25
DO_8	10	DO_24
DO_7	09	DO_23
DO_6	08	DO_22
DO_5	07	DO_21
DO_4	06	DO_20
DO_3	05	DO_19
DO_2	04	DO_18
DO_1	03	DO_17
DO_0	02	DO_16
BK1	01	

37-pin male D-Sub Connector

4.4 Analog Input

4.4.1 F-8015

4.4.1.1 Overview



- 8 RTD input channels
- User defined up/down scale
- Open wire detection
- RoHS compliance
- 3000 V_{DC} isolation from input to backplane
- 3000 V_{DC} isolation from input to frame ground
- Redundancy
- Fast redundant switching time (<100us)

The F-8015 is a 16-bit, 8-channel RTD input module that features programmable input range on all channels. This module has $\pm 0.05\%$ accuracy for highly accurate application. Besides, the F-8015 provides 3000V_{DC} optical isolation between channels and backplane bus. If any high voltage or current damages these channels, this module won't affect other component in iDCS-8000 system.

4.4.1.2 Specification

Parameter	Value	
Feature		
Redundant	Yes (Switching time < 100us)	
Over Voltage Protection	Yes	
Termination board break off detection	Yes	
Open Wire Detection	Yes	
LED indicator	1 RUN, 1 ACT, 1 DUX	
RTD Input		
Number of channels	8	
Type	Pt-100	IEC 60751 ITS90 (0.03851 $\Omega/\Omega/^\circ\text{C}$)
	JPt-100	JIS C 1604 (0.03916 $\Omega/\Omega/^\circ\text{C}$)
	Pt-1000	IEC 60751 ITS90 (0.03851 $\Omega/\Omega/^\circ\text{C}$)
Temperature Range	Pt100	-200 ~ +850
	JPt-100 , Pt1000	-200 ~ +630

Maximum Allowable Input Voltage	120 V _{DC}
Resolution	16 bit
Sampling Rate	8 Samples/sec (Total)
Accuracy	±0.05% FSR (±250 mΩ)
Zero Drift	±0.5 μV/°C
Span Drift	±20 ppm/°C
Common Mode Rejection	106 dB
Normal Mode Rejection	90 dB
Input Impedance	20 MΩ
Data Range	-2500~12500
Isolation	3000V _{DC}
Certification	
EMC	EN61000-6-2, EN61000-6-4 IEC/EN 61000-4-2, IEC/EN 61000-4-4
General	
Termination board	DN-RTD-M
Maximum power consumption	1 W
Operating temperature	-25°C ~ +75°C
Humidity	5 ~ 95 % RH, Non-condensing
Weight	300 g
Dimensions (W x L x H)	30mm x 85mm x 115mm

4.4.1.3 Hardware Structure

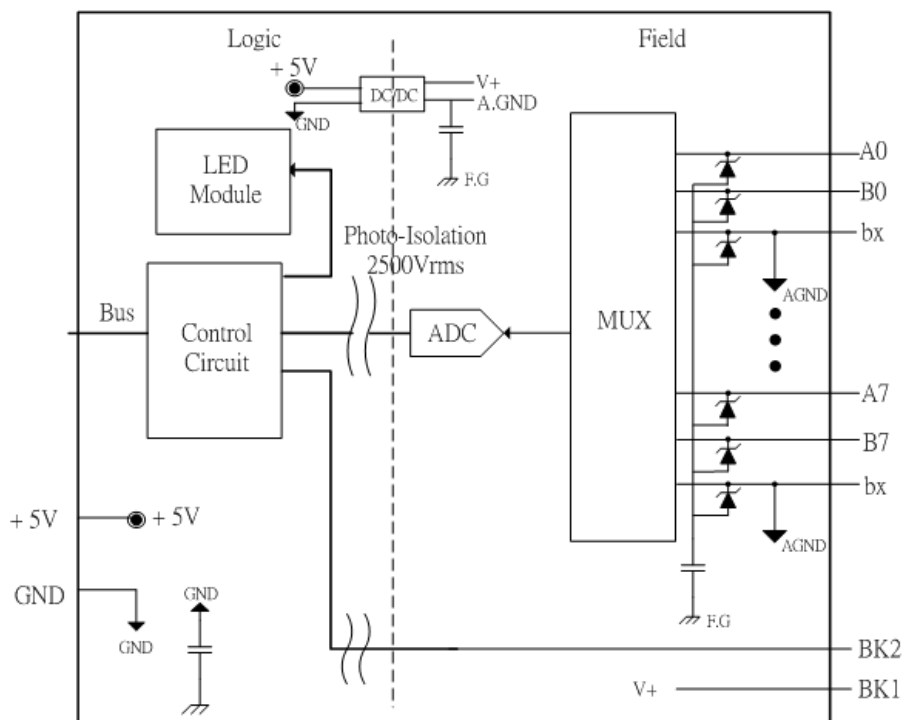

4.4.1.4 Pin assignments

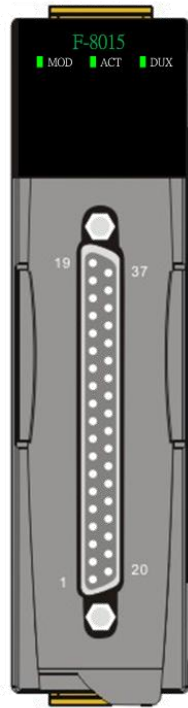

Pin Assignment Name	Terminal No.	Pin Assignment Name
X	19	37 BK2
X	18	36 bx
X	17	35 B7
A7	16	34 X
X	15	33 B6
A6	14	32 X
X	13	31 B5
A5	12	30 X
X	11	29 B4
A4	10	28 X
X	09	27 B3
A3	08	26 X
X	07	25 B2
A2	06	24 X
X	05	23 B1
A1	04	22 X
X	03	21 B0
A0	02	20 X
BK1	01	

37-pin male D-Sub Connector

4.4.2 F-8017C1

4.4.2.1 Overview



- 8 current input channels
- Overrange measurement
- RoHS compliance
- 3000 V_{DC} isolation from input to backplane
- 3000 V_{DC} isolation from input to frame ground
- Redundancy
- Fast redundant switching time (<100us)

The F-8017C1 is a 16-bit, 8-channel analog differential input module. This module accepts current input range 4~20mA and supports 25% over range measurement (Accuracy is not guaranteed). Besides, it has $\pm 0.05\%$ accuracy for highly accurate application. Moreover, this module provides 500Hz sampling rate for some application. The F-8017C1 provides 3000VDC optical isolation between channels and backplane bus. If any high voltage or current damages these channels, this module won't affect other component in iDCS-8000 system.

4.4.2.2 Specification

Parameter	Value
Feature	
Redundant	Yes (Switching time < 100us)
Over-Current Protection	Yes
Termination board break off detection	Yes
LED indicator	1 RUN, 1 ACT, 1 DUX
Analog Input	
Number of channels	8
Type	4~20 mA (Support $\pm 25\%$ overrange)
Maximum Allowable Input Current	25mA
Resolution	16 bit
Sampling Rate	500 Samples/sec (Total)
Accuracy	$\pm 0.05\%$ FSR
Zero Drift	$\pm 20 \mu\text{V}/^\circ\text{C}$
Span Drift	$\pm 25 \text{ ppm}/^\circ\text{C}$
Common Mode Rejection	86 dB
Normal Mode Rejection	100 dB

Input Impedance	230 Ω
Data Range	-2500~12500 (0~24mA)
Isolation	3000V _{DC}
Certification	
EMC	EN61000-6-2, EN61000-6-4 IEC/EN 61000-4-2, IEC/EN 61000-4-4
General	
Termination board	DN-AIO-M
Maximum power consumption	1.5 W
Operating temperature	-25°C ~ +75°C
Humidity	5 ~ 95 % RH, Non-condensing
Weight	300 g
Dimensions (W x L x H)	30mm x 85mm x 115mm

4.4.2.3 Hardware Structure

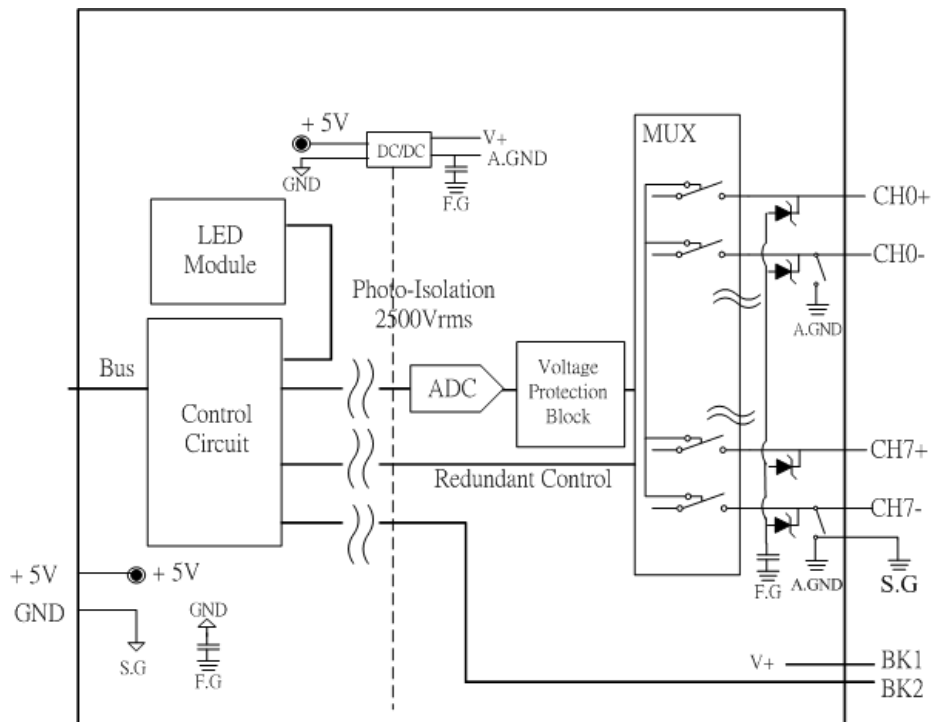

4.4.2.4 Pin assignments

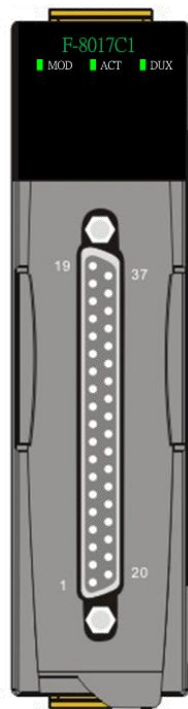

Pin Assignment Name	Terminal No.	Pin Assignment Name
X	19	37 BK2
X	18	36 X
X	17	35 X
X	16	34 X
X	15	33 X
X	14	32 X
X	13	31 X
X	12	30 X
X	11	29 X
X	10	28 X
CH7-	09	27 CH7+
CH6-	08	26 CH6+
CH5-	07	25 CH5+
CH4-	06	24 CH4+
CH3-	05	23 CH3+
CH2-	04	22 CH2+
CH1-	03	21 CH1+
CH0-	02	20 CH0+
BK1	01	

37-pin male D-Sub Connector

4.4.3 F-8017C2

4.4.3.1 Overview



- 16 current input channels
- Overrange measurement
- RoHS compliance
- 3000 V_{DC} isolation from output to backplane
- 3000 V_{DC} isolation from output to frame ground
- Redundancy
- Fast redundant switching time (<100us)

The F-8017C2 is a 16-bit, 16-channel analog differential input module. This module accepts current input range 4~20mA and supports 25% overrange measurement (Accuracy is not guaranteed). Besides, it has $\pm 0.05\%$ accuracy for highly accurate application. Moreover, this module is built-in 2 ADC to provide same sampling rate as F-8017C1 for some application. The F-8017C2 provides 3000VDC optical isolation between channels and backplane bus. If any high voltage or current damages these channels, this module won't affect other component in iDCS-8000 system.

4.4.3.2 Specification

Parameter	Value
Feature	
Redundant	Yes (Switching time < 100us)
Over-Current Protection	Yes
Termination board break off detection	Yes
LED indicator	1 RUN, 1 ACT, 1 DUX
Analog Input	
Number of channels	16
Type	4~20 mA (Support $\pm 25\%$ overrange)
Maximum Allowable Input Current	25mA
Resolution	16 bit
Sampling Rate	500 Samples/sec (Total)
Accuracy	$\pm 0.05\%$ FSR
Zero Drift	$\pm 20 \mu\text{V}/^\circ\text{C}$
Span Drift	$\pm 25 \text{ ppm}/^\circ\text{C}$
Common Mode Rejection	86 dB
Normal Mode Rejection	100 dB

Input Impedance	230 Ω
Data Range	-2500~12500
Isolation	3000V _{DC}
Certification	
EMC	EN61000-6-2, EN61000-6-4 IEC/EN 61000-4-2, IEC/EN 61000-4-4
General	
Termination board	DN-AIO-M
Maximum power consumption	2.2 W
Operating temperature	-25°C ~ +75°C
Humidity	5 ~ 95 % RH, Non-condensing
Weight	300 g
Dimensions (W x L x H)	30mm x 85mm x 115mm

4.4.3.3 Hardware Structure

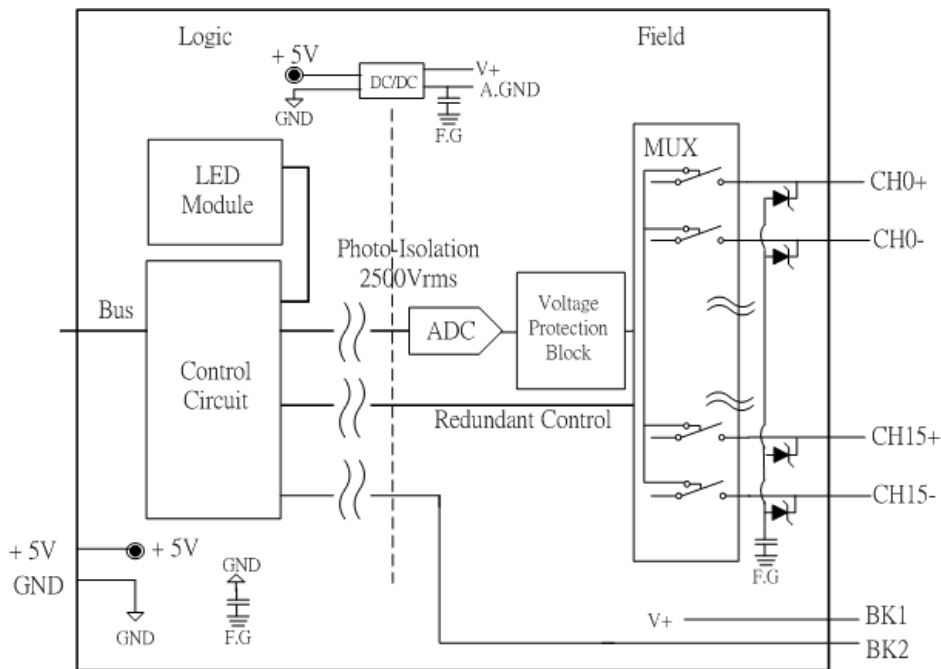

4.4.3.4 Pin assignments

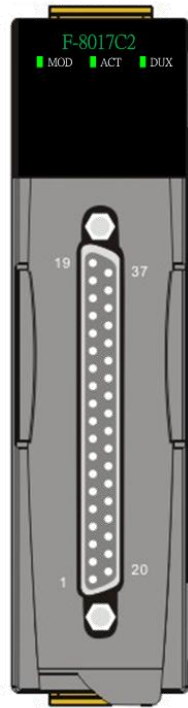

Pin Assignment Name	Terminal No.	Pin Assignment Name
X	19	37 BK2
X	18	36 X
CH15-	17	35 CH15+
CH14-	16	34 CH14+
CH13-	15	33 CH13+
CH12-	14	32 CH12+
CH11-	13	31 CH11+
CH10-	12	30 CH10+
CH9-	11	29 CH9+
CH8-	10	28 CH8+
CH7-	09	27 CH7+
CH6-	08	26 CH6+
CH5-	07	25 CH5+
CH4-	06	24 CH4+
CH3-	05	23 CH3+
CH2-	04	22 CH2+
CH1-	03	21 CH1+
CH0-	02	20 CH0+
BK1	01	

37-pin male D-Sub Connector

4.4.4 F-8017CH

4.4.4.1 Overview



- 8 current input channels
- Overrange measurement
- Built-in HART master interface
- RoHS compliance
- 3000 V_{DC} isolation from input to backplane
- 3000 V_{DC} isolation from input to frame ground
- Redundancy
- Fast redundant switching time (<100us)

The F-8017CH is a 16-bit, 8-channel analog differential input module. This module accepts current input range 4~20mA and supports 25% over range measurement (Accuracy is not guaranteed). Besides, it has $\pm 0.05\%$ accuracy for highly accurate application. Moreover, this module provides 500Hz sampling rate for some application. In addition to current input, F-8017CH is also built-in HART master interface to remotely maintain devices via HART. The F-8017CH provides 3000VDC optical isolation between channels and backplane bus. If any high voltage or current damages these channels, this module won't affect other component in iDCS-8000 system.

4.4.4.2 Specification

Parameter	Value
Feature	
HART interface	Yes, supports HART master
Redundant	Yes (Switching time < 100us)
Over-Current Protection	Yes
Termination board break off detection	Yes
LED indicator	1 RUN, 1 ACT, 1 DUX
Analog Input	
Number of channels	8
Type	4~20 mA (Support $\pm 25\%$ overrange)
Maximum Allowable Input Current	25mA
Resolution	16 bit
Sampling Rate	500 Samples/sec (Total)
Accuracy	$\pm 0.05\%$ FSR
Zero Drift	$\pm 20 \mu\text{V}/^\circ\text{C}$
Span Drift	$\pm 25 \text{ ppm}/^\circ\text{C}$

Common Mode Rejection	86 dB
Normal Mode Rejection	100 dB
Input Impedance	120 Ω
Data Range	-2500~12500
Isolation	3000V _{DC}
HART	
Mode	Master, Monodrop (Point-to-Point)
Certification	
EMC	EN61000-6-2, EN61000-6-4 IEC/EN 61000-4-2, IEC/EN 61000-4-4
General	
Termination board	DN-AIH-08
Maximum power consumption	1.2 W + 7.5W ¹
Operating temperature	-25°C ~ +75°C
Humidity	5 ~ 95 % RH, Non-condensing
Weight	300 g
Dimensions (W x L x H)	30mm x 85mm x 115mm

1. F-8017CH provides the power for the passive loop, so there will be an extra power for the transmitter in the field. The amount of power consumption depends on the number of transmitters.

4.4.4.3 Hardware Structure

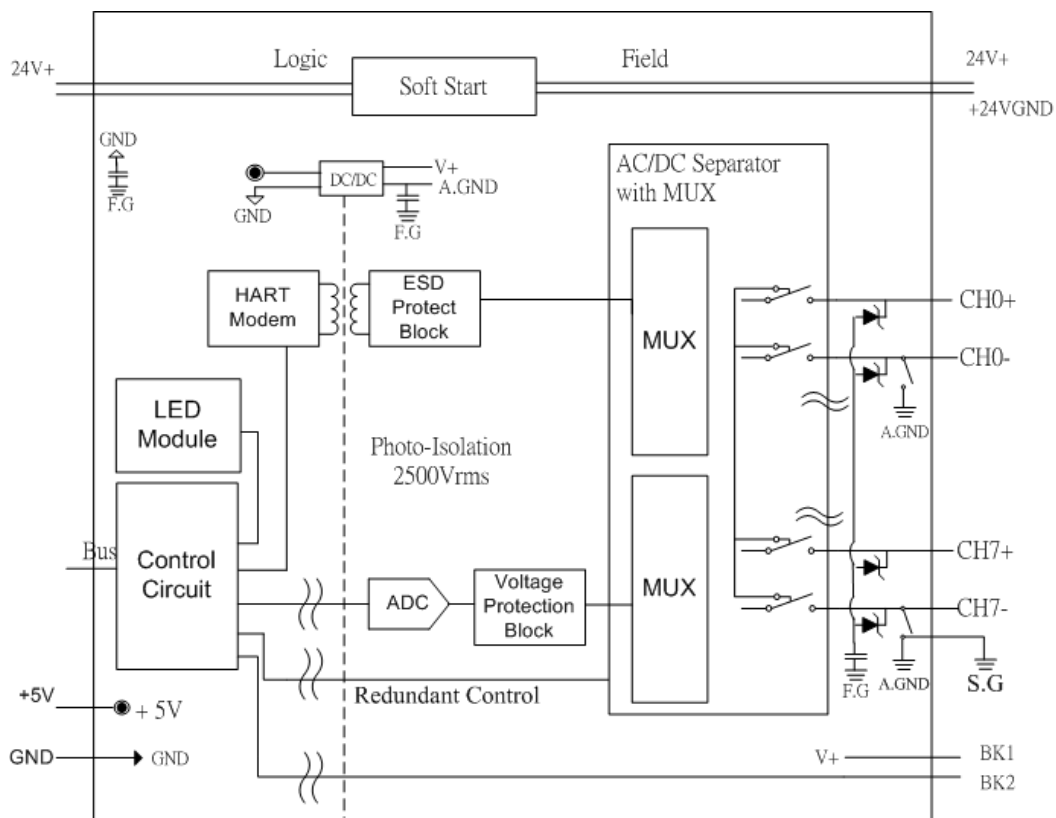

4.4.4.4 Pin assignments

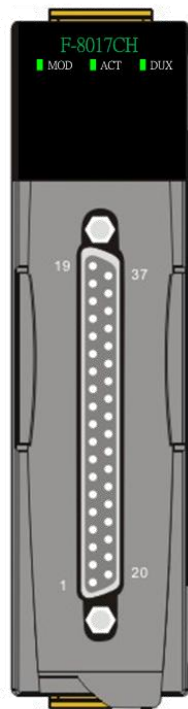

Pin Assignment Name	Terminal No.	Pin Assignment Name
+24V	19	37 BK2
X	18	36 24V.GND
X	17	35 X
X	16	34 X
X	15	33 X
X	14	32 X
X	13	31 X
X	12	30 X
X	11	29 X
X	10	28 X
CH7-	09	27 CH7+
CH6-	08	26 CH6+
CH5-	07	25 CH5+
CH4-	06	24 CH4+
CH3-	05	23 CH3+
CH2-	04	22 CH2+
CH1-	03	21 CH1+
CH0-	02	20 CH0+
BK1	01	

37-pin male D-Sub Connector

4.4.5 F-8019

4.4.5.1 Overview



- 8 thermocouple input channels
- User defined up/down scale
- Open wire detection
- RoHS compliance
- 3000 V_{DC} isolation from input to backplane
- 3000 V_{DC} isolation from input to frame ground
- Redundancy
- Fast redundant switching time (<100us)

The F-8019 is a 16-bit, 8-channel thermocouple input module that features programmable input range on all channels. It measures millivolt input ($\pm 15\text{mV}$, $\pm 50\text{mV}$, $\pm 100\text{mV}$, $\pm 150\text{mV}$, $\pm 500\text{mV}$), voltage input ($\pm 1\text{V}$, $\pm 2.5\text{V}$, $\pm 5\text{V}$, $\pm 10\text{V}$) and thermocouple input (Type J, K, T, E, R, S, B, N, C). An external CJC is supported for accurate temperature measurement. Moreover, this module has $\pm 0.05\%$ accuracy for highly accurate application. Besides, the F-8019 provides 3000V_{DC} optical isolation between channels and backplane bus. If any high voltage or current damages these channels, this module won't affect other component in iDCS-8000 system.

4.4.5.2 Specification

Parameter	Value	
Feature		
Redundant	Yes (Switching time < 100us)	
Over Voltage Protection	Yes	
Termination board break off detection	Yes	
Open Wire Detection	Yes	
LED indicator	1 RUN, 1 ACT, 1 DUX	
Thermocouple Input		
Number of channels	8	
Type	$\pm 15\text{mV}$, $\pm 50\text{mV}$, $\pm 100\text{mV}$, $\pm 150\text{mV}$, $\pm 500\text{mV}$, $\pm 1\text{V}$, $\pm 2.5\text{V}$, $\pm 5\text{V}$, $\pm 10\text{V}$, Type J, K, T, E, R, S, B, N, C	
Temperature Range	J	-210 ~ +1200 °C
	K	-270 ~ +1372 °C
	T	-270 ~ +400 °C
	E	-270 ~ +1000 °C

	R	-50 ~ +1765 °C
	S	-50 ~ +1765 °C
	B	0 ~ +1820 °C
	N	-270 ~ +1300 °C
	C	0 ~ +2320 °C
Maximum Allowable Input Voltage	120 V _{DC}	
Resolution	16 bit	
Sampling Rate	8 Samples/sec (Total)	
Accuracy	±0.05% FSR	
Zero Drift	±0.5 μV/°C	
Span Drift	±20 ppm/°C	
Common Mode Rejection	106 dB	
Normal Mode Rejection	90 dB	
Input Impedance	10 MΩ	
Data Range	-2500~12500	
Isolation	3000V _{DC}	
Certification		
EMC	EN61000-6-2, EN61000-6-4 IEC/EN 61000-4-2, IEC/EN 61000-4-4	
General		
Termination board	DN-TC-M	
Maximum power consumption	1.3 W	
Operating temperature	-25°C ~ +75°C	
Humidity	5 ~ 95 % RH, Non-condensing	
Weight	300 g	
Dimensions (W x L x H)	30mm x 85mm x 115mm	

4.4.5.3 Hardware Structure

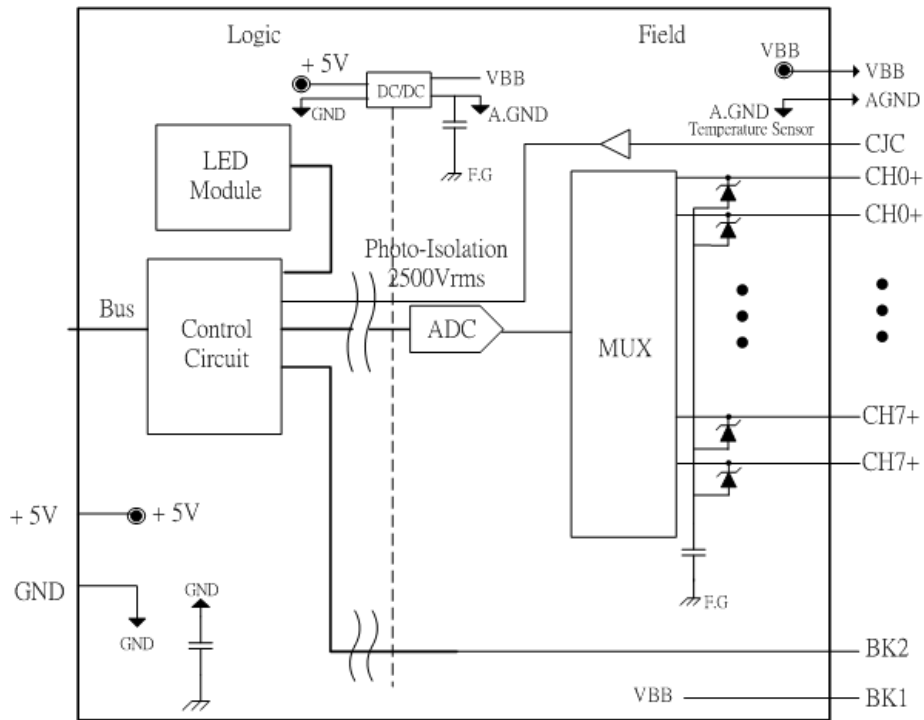

4.4.5.4 Pin assignments

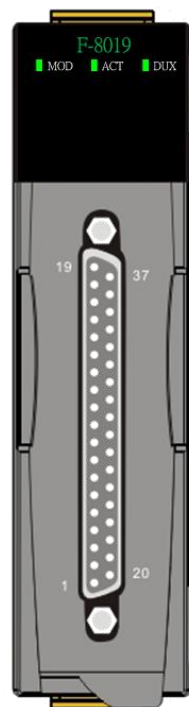

Pin Assignment Name	Terminal No.	Pin Assignment Name
CJC	19	BK2
VBB	18	AGND
X	17	X
X	16	X
X	15	X
X	14	X
X	13	X
X	12	X
X	11	X
X	10	X
X	09	X
CH7-	08	CH7+
CH6-	08	CH6+
CH5-	07	CH5+
CH4-	06	CH4+
CH3-	05	CH3+
CH2-	04	CH2+
CH1-	03	CH1+
CH0-	02	CH0+
BK1	01	

37-pin male D-Sub Connector

4.5 Analog Output

4.5.1 F-8028CV

4.5.1.1 Overview



- 8 current/voltage output channels
- Overrange output
- Short circuit protection
- Open wire detection
- RoHS compliance
- 3000 V_{DC} isolation from output to backplane
- 3000 V_{DC} isolation from output to frame ground
- Redundancy
- Fast redundant switching time (<1 ms)

The F-8028CV is a 16-bit, 8-channel analog output module that features programmable output range on all channels. It provides digital to analog converter controlled by the system module to convert the digital data into output signals. Users can specify the start up and safety value through configuration software. Moreover, this module has $\pm 0.05\%$ accuracy for highly accurate application. Besides, the F-8028CV provides 3000V_{DC} optical isolation between channels and backplane bus. If any high voltage or current damages these channels, this module won't affect other component in iDCS-8000 system.

4.5.1.2 Specification

Parameter	Value
Feature	
Redundant	Yes (Switching time < 1 ms)
Termination board break off detection	Yes
Short Circuit Protection	Yes
Open Wire Detection	Yes (4 ~ 20 mA)
Power-On Value	Yes
Safety Value	Yes
LED indicator	1 RUN, 1 ACT, 1 DUX
Analog Output	
Number of channels	8
Type	0 ~ 20 mA, 4 ~ 20 mA (current sourcing) 0 ~ 5 V, ± 5 V, 0 ~ 5 V, ± 10 V
Maximum Allowable Output Range	0 ~ 20 mA +20% (0 ~ 24 mA)

	4 ~ 20 mA	±25% (0 ~ 24 mA)
	0 ~ 5 V	+20% (0 ~ 6 V)
	±5 V	±20% (±6V)
	0 ~ 5 V	+20% (0 ~ 12 V)
	±10 V	±20% (±12V)
Resolution	16 bit	
Output Response Time	<200 μS	
Accuracy	±0.05% FSR	
Zero Drift	±0.2 μV/°C	
Span Drift	±25 ppm/°C	
Output Capacity	Current	750 Ω
	Voltage	500 Ω
Data Range	-2500~12500	
Isolation	3000V _{DC}	
Certification		
EMC	EN61000-6-2, EN61000-6-4	
	IEC/EN 61000-4-2, IEC/EN 61000-4-4	
General		
Termination board	DN-AIO-M	
Maximum power consumption	0.5 W + 11 W ¹	
Operating temperature	-25°C ~ +75°C	
Humidity	5 ~ 95 % RH, Non-condensing	
Weight	300 g	
Dimensions (W x L x H)	30mm x 85mm x 115mm	

1. The power consumption depends on the load.

4.5.1.3 Hardware Structure

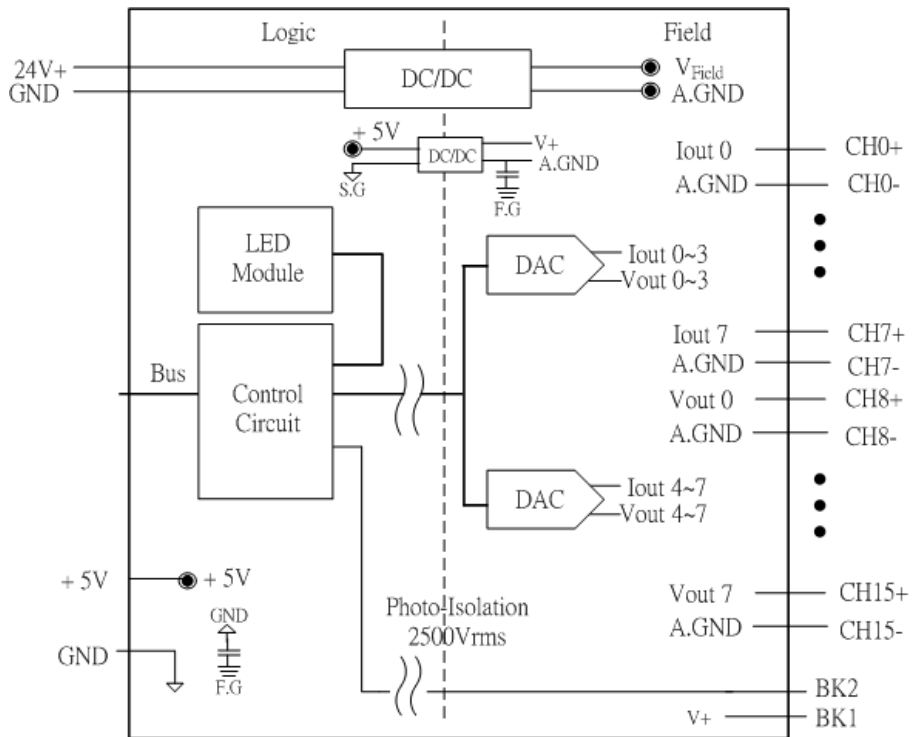

4.5.1.4 Pin assignments

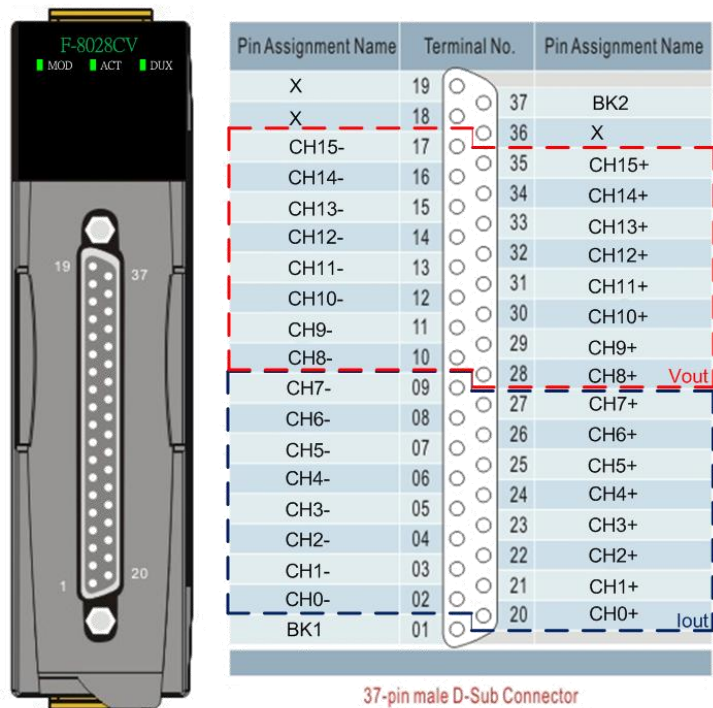

NOTE: The voltage output will start from channel 8.

4.5.2 F-8028CH

4.5.2.1 Overview



- 8 current output channels
- Built-in HART master interface
- Overrange output
- Open wire detection
- RoHS compliance
- 3000 V_{DC} isolation from output to backplane
- 3000 V_{DC} isolation from output to frame ground
- Redundancy
- Fast redundant switching time (<1 ms)

The F-8028CH is a 16-bit, 8-channel analog output module. It provides digital to analog converter controlled by the system module to convert the digital data into output signals. Users can specify the start up and safety value through configuration software. Moreover, this module has $\pm 0.05\%$ accuracy for highly accurate application. In addition to current output, F-8028CH is also built-in HART master interface to remotely maintain devices via HART. Besides, the F-8028CH provides 3000V_{DC} optical isolation between channels and backplane bus. If any high voltage or current damages these channels, this module won't affect other component in iDCS-8000 system.

4.5.2.2 Specification

Parameter	Value
Feature	
HART interface	Yes, supports HART master
Redundant	Yes (Switching time < 1 ms)
Termination board break off detection	Yes
Open Wire Detection	Yes
Power-On Value	Yes
Safety Value	Yes
LED indicator	1 RUN, 1 ACT, 1 DUX
Analog Output	
Number of channels	8
Type	4 ~ 20 mA, current sourcing
Maximum Allowable Output Range	$\pm 25\%$ (0 ~ 24 mA)
Resolution	16 bit
Output Response Time	<200 μ S
Accuracy	$\pm 0.05\%$ FSR

Zero Drift	$\pm 0.2 \mu\text{V}/^\circ\text{C}$
Span Drift	$\pm 25 \text{ ppm}/^\circ\text{C}$
Output Capacity	0 ~ 750 Ω
Data Range	-2500~12500
Isolation	3000V _{DC}
HART	
Mode	Master, Monodrop (Point-to-Point)
Certification	
EMC	EN61000-6-2, EN61000-6-4 IEC/EN 61000-4-2, IEC/EN 61000-4-4
General	
Termination board	DN-AIO-M
Maximum power consumption	0.5 W + 10W ¹
Operating temperature	-25°C ~ +75°C
Humidity	5 ~ 95 % RH, Non-condensing
Weight	300 g
Dimensions (W x L x H)	30mm x 85mm x 115mm

1. The power consumption depends on the load.

4.5.2.3 Hardware Structure

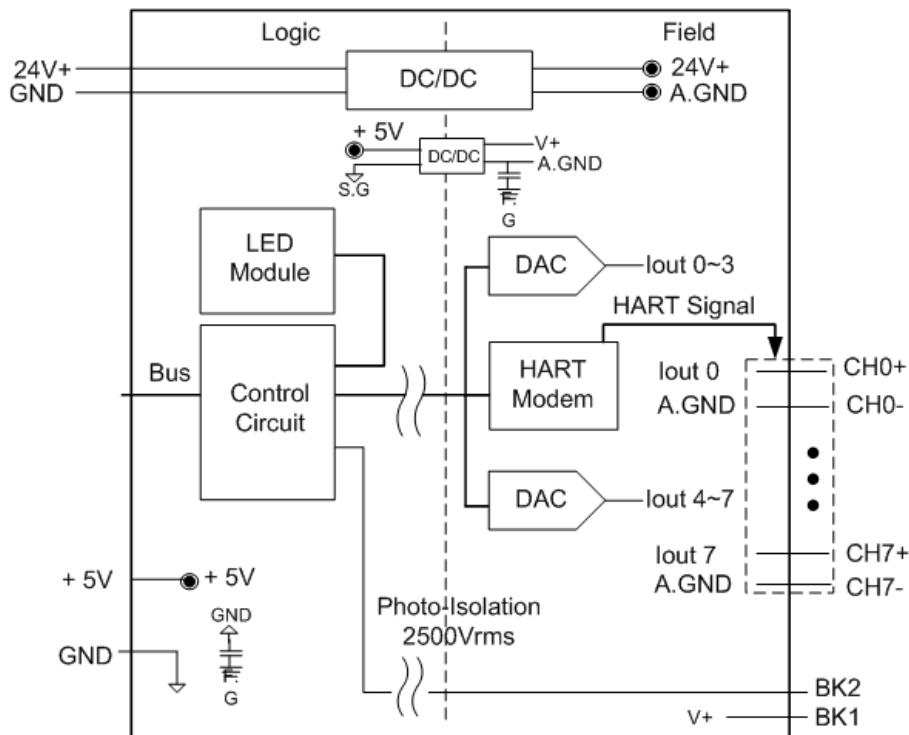

4.5.2.4 Pin assignments

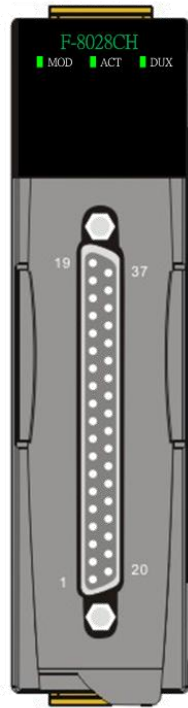

Pin Assignment Name	Terminal No.	Pin Assignment Name
X	19	37 BK2
X	18	36 X
X	17	35 X
X	16	34 X
X	15	33 X
X	14	32 X
X	13	31 X
X	12	30 X
X	11	29 X
X	10	28 X
CH7-	09	27 CH7+
CH6-	08	26 CH6+
CH5-	07	25 CH5+
CH4-	06	24 CH4+
CH3-	05	23 CH3+
CH2-	04	22 CH2+
CH1-	03	21 CH1+
CH0-	02	20 CH0+
BK1	01	

37-pin male D-Sub Connector

4.6 Pulse Input

4.6.1 F-8084

4.6.1.1 Overview



- 32-bit counter
- 8 up-counter/ frequency channels
- 1 ~ 32767 us digital filter
- Falling/Rising/Both edge trigger
- RoHS compliance
- 3000 VDC isolation from output to backplane
- 3000 VDC isolation from output to frame ground
- Redundancy
- No error counting when redundant switching

The F-8084 is a 32-bit high speed up-counter/frequency module. It can count up to 500 KHz input signal, and accuracy of the frequency mode is +/-0.4% FSR. The F-8084 features many diagnostic like some failures of communication, EEPROM, WDT, decoder, etc. When the modules are in the redundant mode and a failure occurs the slave module will take over as soon as possible. Moreover, the redundant switching is not only fast but also reliable for data exchanging. Thus, users can easily to use F-8084 to count.

4.6.1.2 Specification

Parameter	Value
Feature	
Redundant	Yes (The counting error less than 1 counter when input signal < 10 KHz)
Termination board break off detection	Yes
Digital filter	Yes (1~32767us)
LED indicator	1 RUN, 1 ACT, 1 DUX
Pulse Input	
Number of channels	8
Type	Counter/Frequency
Min. Pulse Width	2 us
Input Frequency Range	1 Hz ~ 500 KHz
Rated Voltage	30 V _{DC}
Input voltage range, "1"	4.5 V _{DC} ~ 30 V _{DC}
Input voltage range, "0"	< 1 V _{DC}

Detection time	2 us
Input impedance	200/500/1KΩ or none (5 KΩ)
Nominal input channel current	20mA @ 24V _{DC}
Maximum input current	25mA @ 30V _{DC}
Certification	
EMC	EN61000-6-2, EN61000-6-4 IEC/EN 61000-4-2, IEC/EN 61000-4-4
General	
Termination board	DN-PI-M
Maximum power consumption	1.9 W
Operating temperature	-25°C ~ +75°C
Humidity	5 ~ 95 % RH, Non-condensing
Weight	300 g
Dimensions (W x L x H)	30mm x 85mm x 115mm

4.6.1.3 Hardware Structure

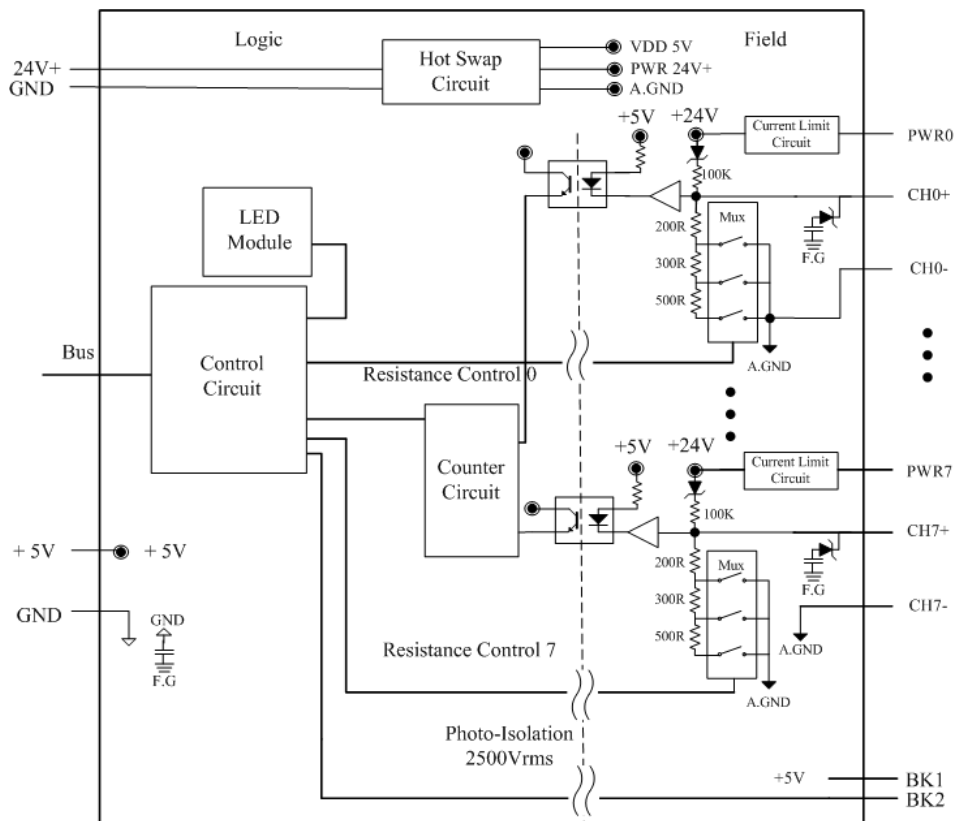

4.6.1.4 Pin assignments

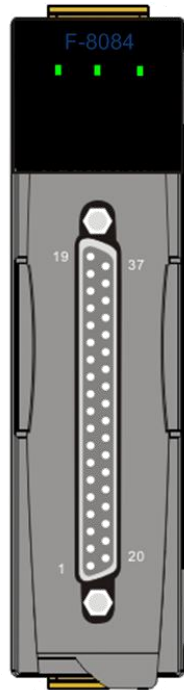

Pin Assignment Name	Terminal No.	Pin Assignment Name
BP_24V+	19	37 BK2
X	18	36 X
X	17	35 CH7+
CH7-	16	34 X
X	15	33 CH6+
CH6-	14	32 X
X	13	31 CH5+
CH5-	12	30 X
X	11	29 CH4+
CH4-	10	28 X
X	09	27 CH3+
CH3-	08	26 X
X	07	25 CH2+
CH2-	06	24 X
X	05	23 CH1+
CH1-	04	22 X
X	03	21 CH0+
CH0-	02	20 X
BK1	01	

37-pin male D-Sub Connector

Section 5 Termination Board

5.1 Digital Input

5.1.1 DN-DIO-M

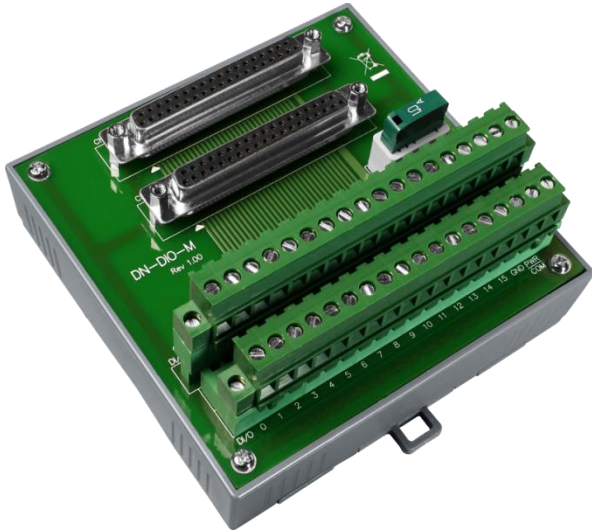

5.1.1.1 Overview

The DN-DIO-M is a termination board for digital input and output modules. The size of DN-DIO-M is relatively small than other termination boards. Due to the small size of termination board, the DN-DIO-M can be fulfilled some applications in small cabinet.

5.1.1.2 Specification

Digital Input	
Type	Wet contact (Current sinking/sourcing)
Channel	32
General	
Dimension (W x L x H)	112 x 117 x 29 mm
Mounting	35 mm DIN Rail, Wall
Operating temperature	-25 ~ 75°C
Humidity	5 ~ 95 % RH, Non-condensing

5.1.1.3 Pin assignment

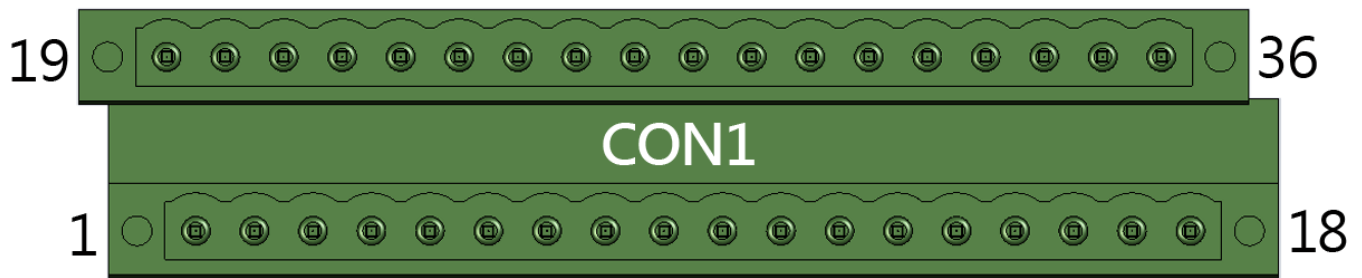

19	20	21	22	23	24	25	26	27	28	29	30	31	32	33	34	35	36
DI16	DI17	DI18	DI19	DI20	DI21	DI22	DI23	DI24	DI25	DI26	DI27	DI28	DI29	DI30	DI31	N/A	COM
1	2	3	4	5	6	7	8	9	10	11	12	13	14	15	16	17	18
DI0	DI1	DI2	DI3	DI4	DI5	DI6	DI7	DI8	DI9	DI10	DI11	DI12	DI13	DI14	DI15	N/A	COM

5.1.1.4 Wiring

- Wet contact (Current sinking / sourcing)

Input Type	ON State LED ON Readback as 0	OFF State LED OFF Readback as 1
Relay Contact	Relay ON	Relay Off
TTL/CMOS Logic	Voltage > 3.5V	Voltage < 1V
NPN Output	Open Collector On	Open Collector Off
PNP Output	Open Collector On	Open Collector Off

5.1.2 DN-DI-32DW

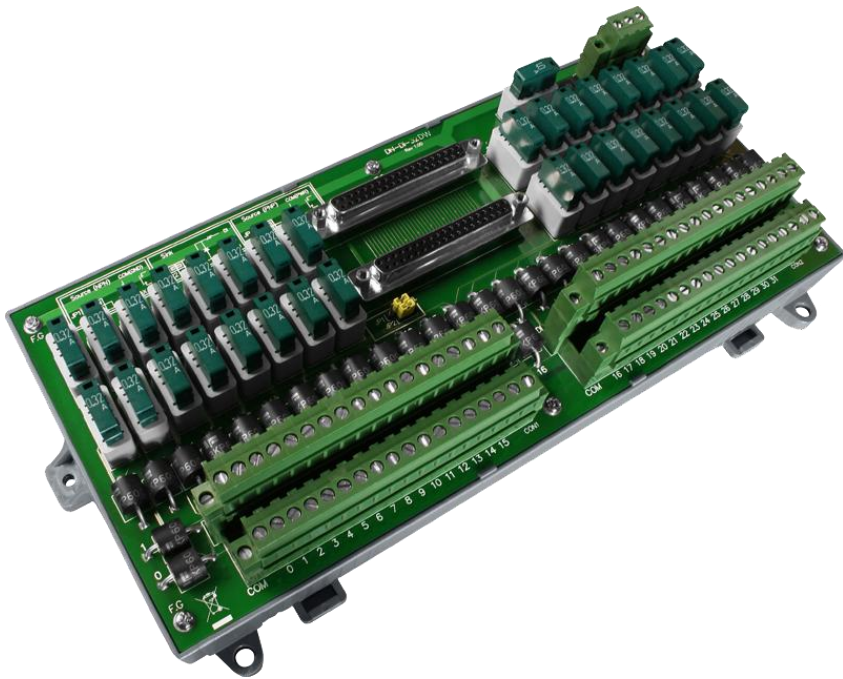

5.1.2.1 Overview

The DN-DI-32DW is a termination board with EMS protection. It provides sink and source connections for comprehensive applications. Moreover, the DN-DI-32DW supports wet and dry contact to fulfill most applications. In addition, this board also offers each channel one COM pin, the benefit for users is that they need no more additional terminal block for extending COM. Furthermore, the DN-DI-32DW offers removable fuse protection for the field loops with local indication of fuse failure and overvoltage and transient protection.

5.1.2.2 Specification

Digital Input		
Type	*Wet contact (Current sinking/sourcing) *Dry contact (Current sinking/sourcing)	
Channel	32	
Fuse ratings	350mA for each channel (With physical indication)	
Transient protection	Peak Power Dissipation	3000W
	Peak Forward Surge Current	250A
General		
Dimension (W x L x H)	126.6 x 274.6 x 25.5 mm	
Mounting	35 mm DIN Rail, Wall	
Operating temperature	-25 ~ 75°C	
Humidity	5 ~ 95 % RH, Non-condensing	

*Wet/Dry contact is Jumper selectable

5.1.2.3 Hardware structure

- F-8040 with DN-DI-32DW (Dry contact – Current sourcing)

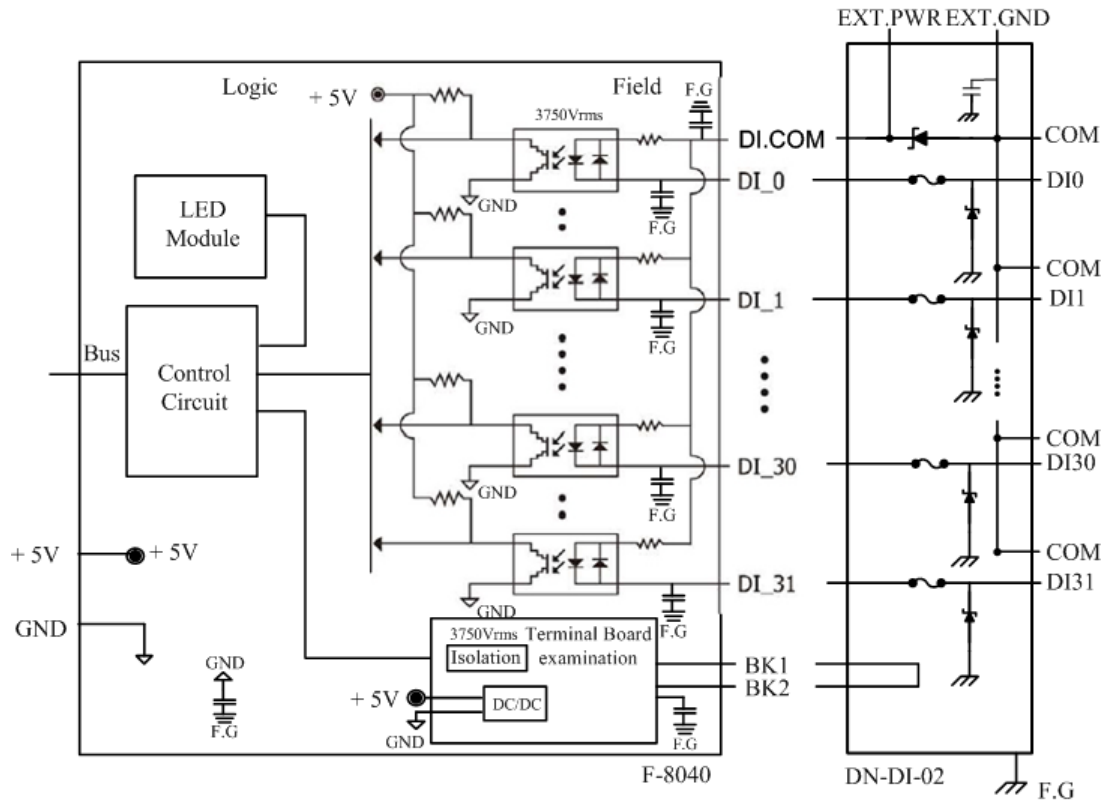

- F-8040 with DN-DI-32DW (Dry contact – Current sinking)

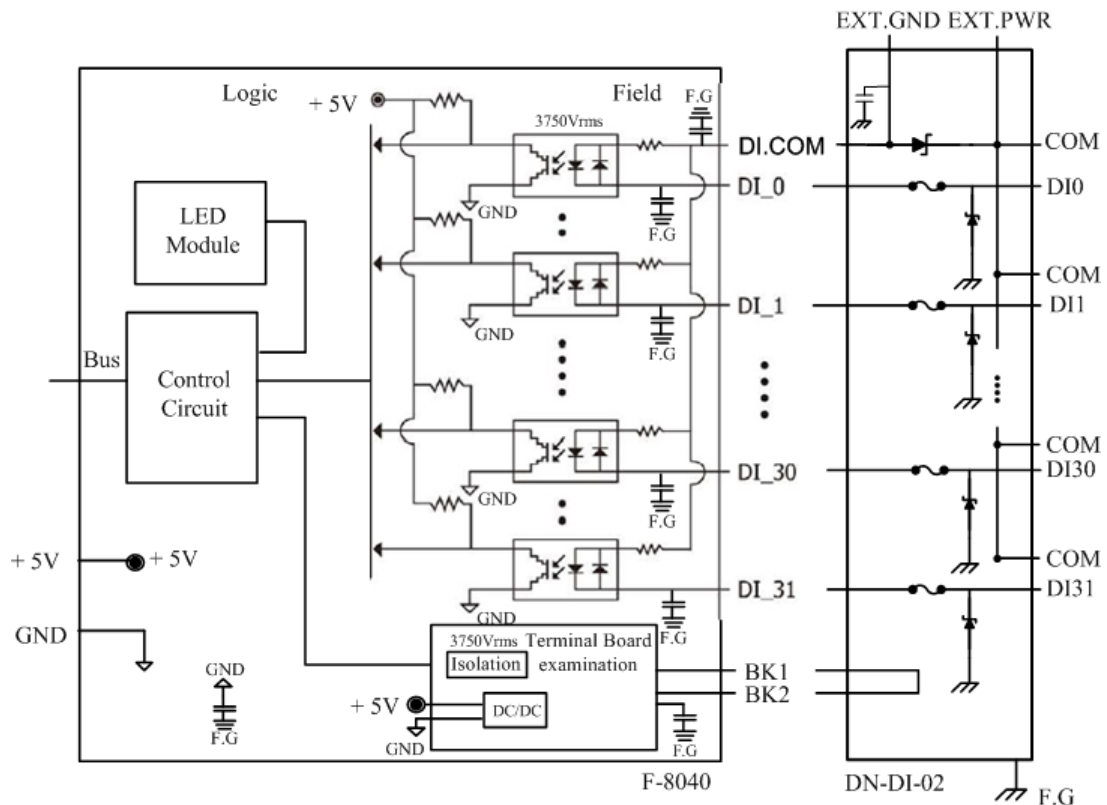

● F-8040 with DN-DI-32DW (Wet contact – Current sinking or sourcing)

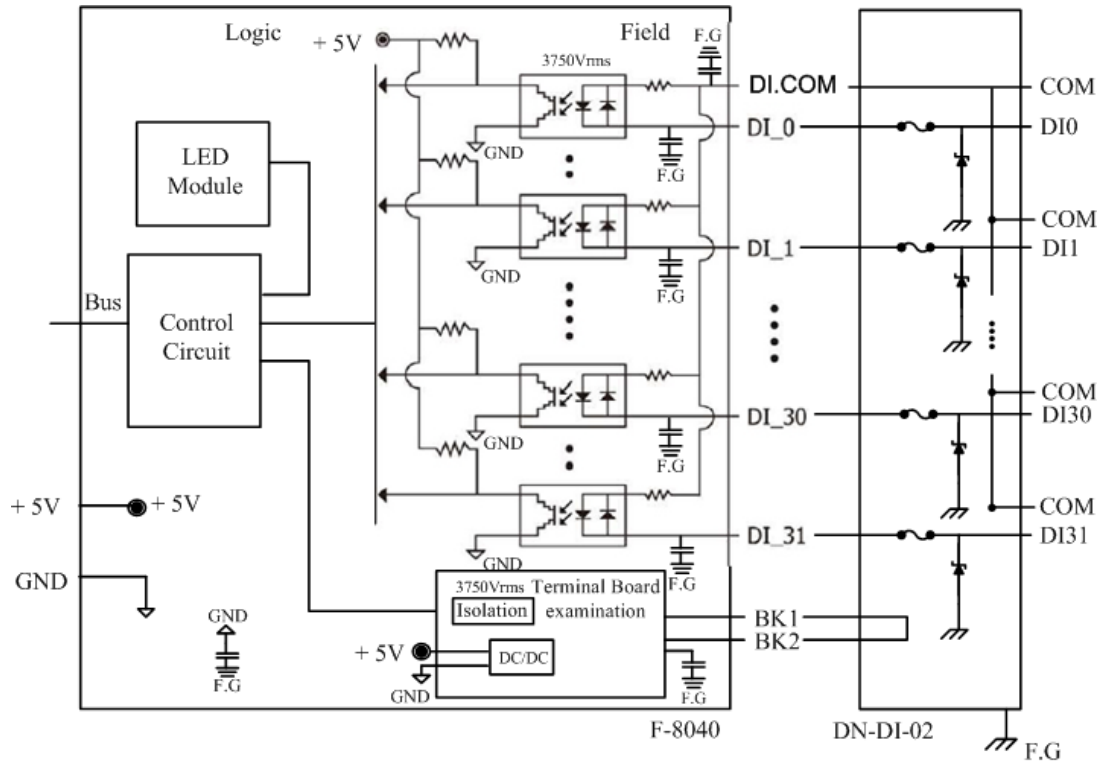

5.1.2.4 Jumper Setting

The DN-DI-32DW offers various wire connections to connect with field device to digital input module. It can be switched to different wire connection by changing jumper setting. The detail of jumper settings are described as following table.

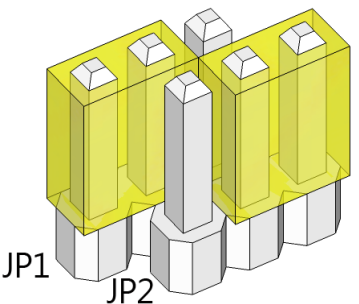
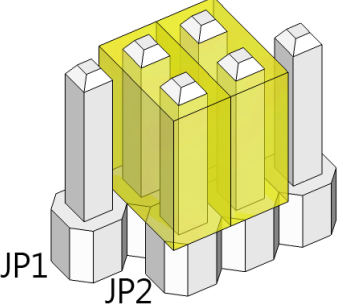
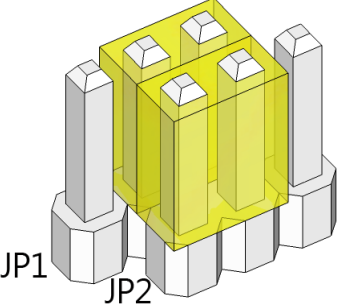
		
<p>Wet Contact Current Sinking / Sourcing</p>	<p>Dry Contact Current Sinking</p>	<p>Dry Contact Current Sourcing</p>

NOTE: Please make sure the external power is attached as well when use dry contact wire connection.

5.1.2.5 Pin Assignment

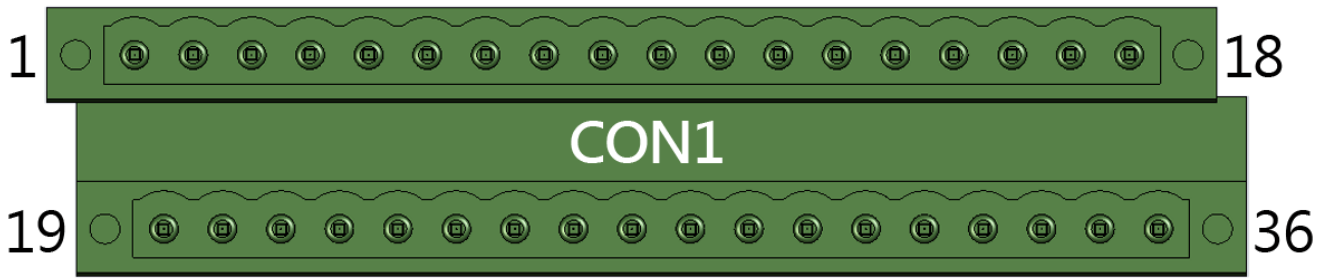

1	2	3	4	5	6	7	8	9	10	11	12	13	14	15	16	17	18
NC	DI0	DI1	DI2	DI3	DI4	DI5	DI6	DI7	DI_8	DI9	DI10	DI11	DI12	DI13	DI14	DI15	NC
19	20	21	22	23	24	25	26	27	28	29	30	31	32	33	34	35	36
NC	COM	COM	COM	COM	COM	COM	COM	COM	COM	COM	COM	COM	COM	COM	COM	COM	NC

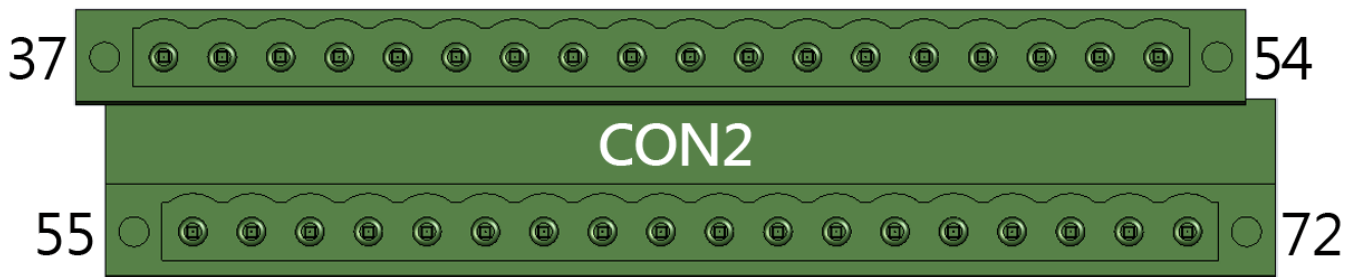

37	38	39	40	41	42	43	44	45	46	47	48	49	50	51	52	53	54
NC	DI16	DI17	DI18	DI19	DI20	DI21	DI22	DI23	DI24	DI25	DI26	DI27	DI28	DI29	DI30	DI31	NC
55	56	57	58	59	60	61	62	63	64	65	66	67	68	69	70	71	72
NC	COM	COM	COM	COM	COM	COM	COM	COM	COM	COM	COM	COM	COM	COM	COM	COM	NC

5.1.2.6 Wiring

- Dry contact (Current sourcing)

Input Type	On State, LED On Readback as 1	Off State, LED Off Readback as 0
Relay Contact	Relay On 	Relay Off
	TTL/CMOS Logic Voltage < 1V 	TTL/CMOS Logic Voltage > 3.5V
Open Collector	Open Collector On 	Open Collector Off

- Dry contact (Current sinking)

Input Type	ON State LED ON Readback as 0	OFF State LED OFF Readback as 1
Relay Contact	Relay ON 	Relay Off
	NPN Output Open Collector On 	NPN Output Open Collector Off
PNP Output	Open Collector On 	Open Collector Off

- Wet contact (Current sinking / sourcing)

Input Type	ON State LED ON Readback as 0	OFF State LED OFF Readback as 1
Relay Contact	Relay ON	Relay Off
TTL/CMOS Logic	Voltage > 3.5V	Voltage < 1V
NPN Output	Open Collector On	Open Collector Off
PNP Output	Open Collector On	Open Collector Off

5.2 Digital Output

5.2.1 DN-DIO-M

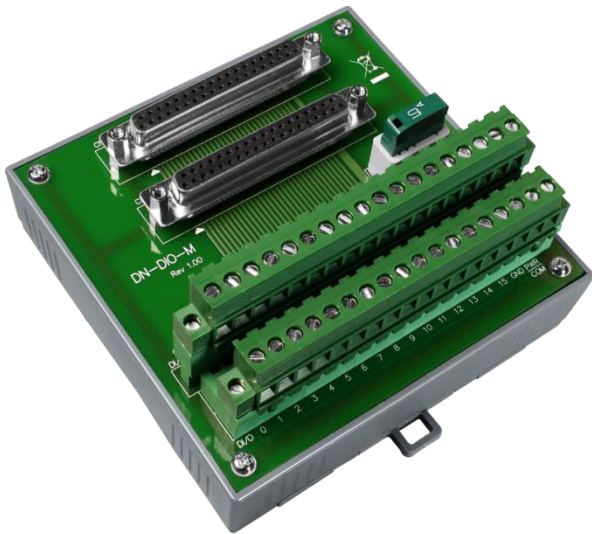

5.2.1.1 Overview

The DN-DIO-M is a termination board for digital input and output modules. The size of DN-DIO-M is relatively small than other termination boards. Due to the small size of termination board, the DN-DIO-M can be fulfilled some applications in small cabinet.

5.2.1.2 Specification

Digital Output	
Type	Current sinking, Open-collector
Channel	32
General	
Dimension (W x L x H)	112 x 117 x 29 mm
Mounting	35 mm DIN Rail, Wall
Operating temperature	-25 ~ 75°C
Humidity	5 ~ 95 % RH, Non-condensing

5.2.1.3 Pin assignment

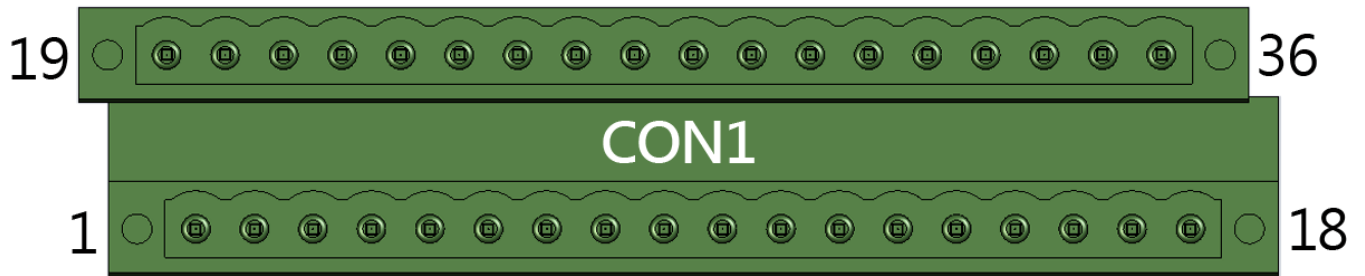

19	20	21	22	23	24	25	26	27	28	29	30	31	32	33	34	35	36
DO16	DO17	DO18	DO19	DO20	DO21	DO22	DO23	DO24	DO25	DO26	DO27	DO28	DO29	DO30	DO31	GND	PWR
1	2	3	4	5	6	7	8	9	10	11	12	13	14	15	16	17	18
DO0	DO1	DO2	DO3	DO4	DO5	DO6	DO7	DO8	DO9	DO10	DO11	DO12	DO13	DO14	DO15	GND	PWR

5.2.1.4 Wiring

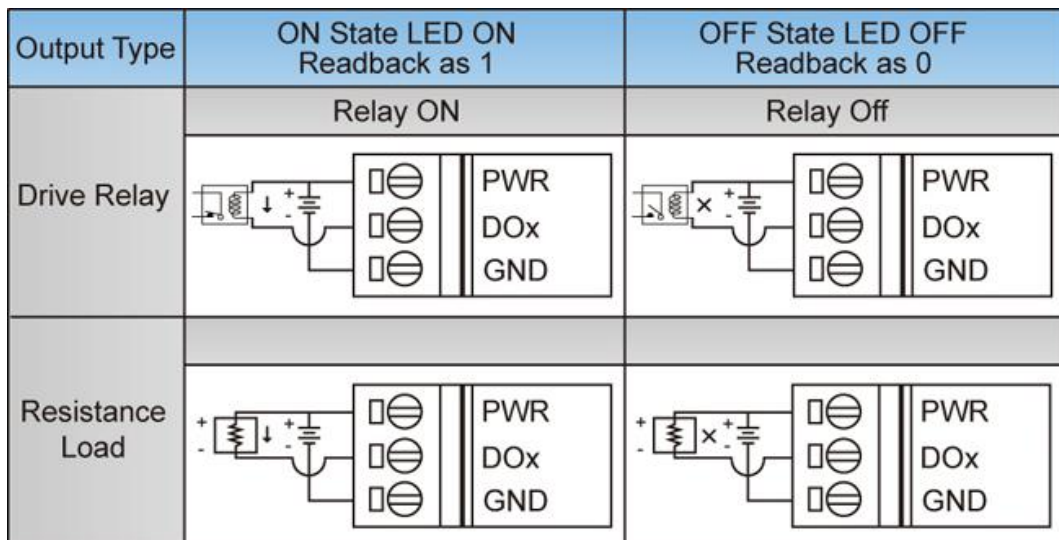

5.2.2 DN-DO-16DR-A & DN-DO-16DR-B



5.2.2.1 Overview

The DN-DO-16DR-A & DN-DO-16DR-B are termination boards with relay (Form C, SPDT) output. The DN-DO-16DR-A is used for digital output channel 0~15, and the DN-DO-16DR-B is used for digital output channel 16~31. These boards offer 2 output for each channel to extend control logic due to the Form C relay, it can be positive (N.O.) or negative (N.C.) logic output or both. In addition, each channel is built-in two varistors on N.O. and N.C. channel to protect against high-voltage transients and surges to the control loop.

5.2.2.2 Specification

Model	DN-DO-16DR-A	DN-DO-16DR-B
Digital Output		
Channel	16 (DO0~15)	16 (DO16~31)
Type	Form C Relay	
Relay Contact		
Contact configuration	SPDT	
Rated current/Max. peak current	6A/10A	
Rated voltage/Max. switching voltage	250 V _{AC} /400V _{AC}	
Minimum switching Load	300 mW	
Mechanical life	20 x 10 ⁶	
Operate/release time	8/5 ms	
Relay Coil		
Voltage input	24V _{DC} ± 10%	
Current consumption	400mA@24V _{DC}	
Varistor Protection		
Max. applied voltage (Continuous)	AC: 300 V _{rms} DC: 385 V _{DC}	
Rated voltage	470Vrms	
General		
Dimension (W x L x H)	126.6 x 274.6 x 25.5 mm	
Mounting	35 mm DIN Rail, Wall	
Ambient Temperature	-25 ~ 75°C	
Humidity	5 ~ 95 % RH, Non-condensing	

5.2.2.3 Hardware structure

- F-8041 with DN-DO-16DR-A & DN-DO-16DR-B

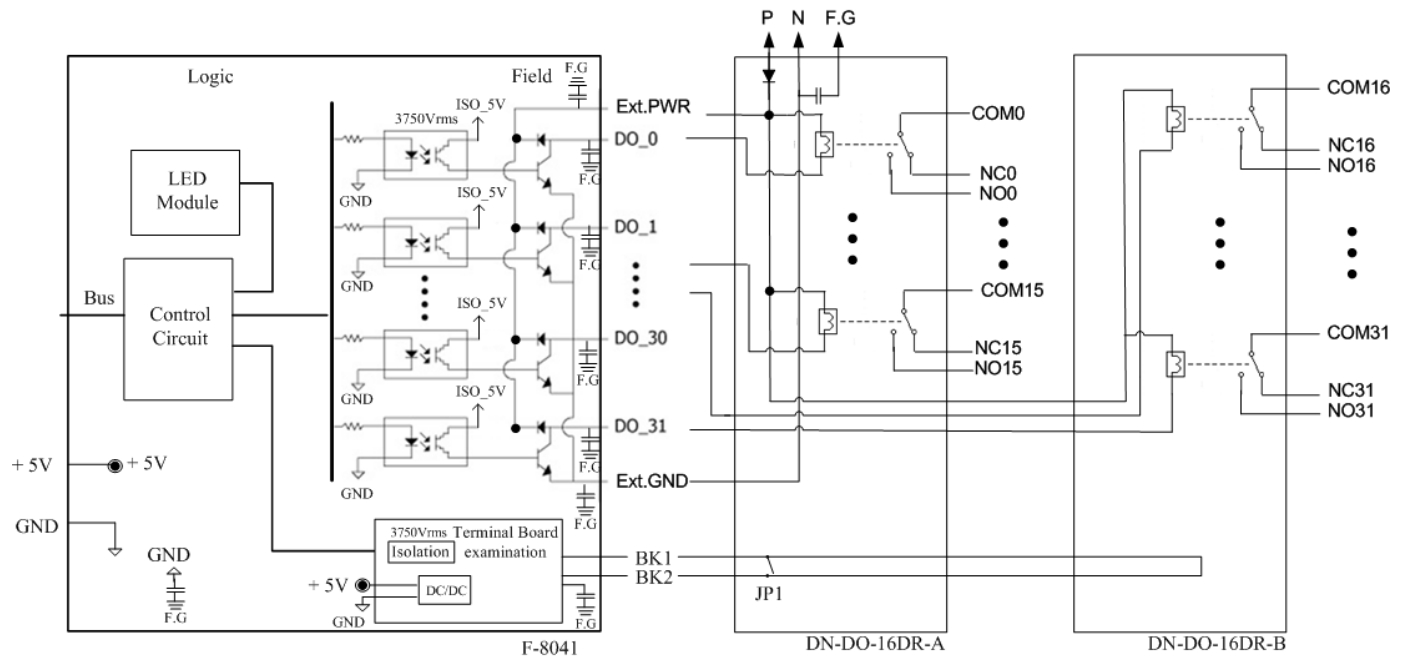

5.2.2.4 Pin Assignment

- DN-DO-16DR-A

CN4

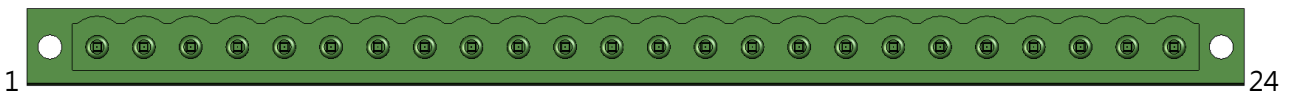

1	2	3	4	5	6	7	8	9	10	11	12
NO0	NC0	COM0	NO1	NC1	COM1	NO2	NC2	COM2	NO3	NC3	COM3
13	14	15	16	17	18	19	20	21	22	23	24
NO4	NC4	COM4	NO5	NC5	COM5	NO6	NC6	COM6	NO7	NC7	COM7

CN5

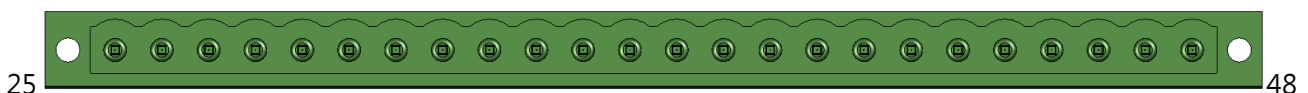

25	26	27	28	29	30	31	32	33	34	35	36
NO8	NC8	COM8	NO9	NC9	COM9	NO10	NC10	COM10	NO11	NC11	COM11
37	38	39	40	41	42	43	44	45	46	47	48
NO12	NC12	COM12	NO13	NC13	COM13	NO14	NC14	COM14	NO15	NC15	COM15

● DN-DO-16DR-B

CON1

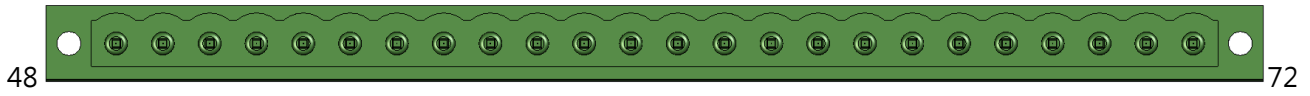

49	50	51	52	53	54	55	56	57	58	59	60
NO16	NC16	COM16	NO17	NC17	COM17	NO18	NC18	COM18	NO19	NC19	COM19
61	62	63	64	65	66	67	68	69	70	71	72
NO20	NC20	COM20	NO21	NC21	COM21	NO22	NC22	COM22	NO23	NC23	COM23

CON2

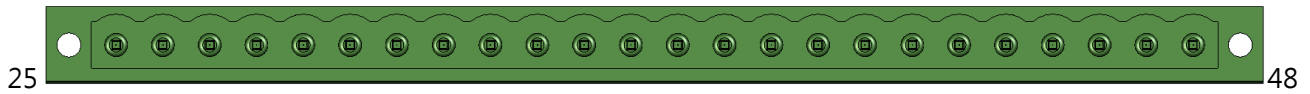

73	74	75	76	77	78	79	80	81	82	83	84
NO24	NC24	COM24	NO25	NC25	COM25	NO26	NC26	COM26	NO27	NC27	COM27
85	86	87	88	89	90	91	92	93	94	95	96
NO28	NC28	COM28	NO29	NC29	COM29	NO30	NC30	COM30	NO31	NC31	COM31

5.2.2.5 Wiring

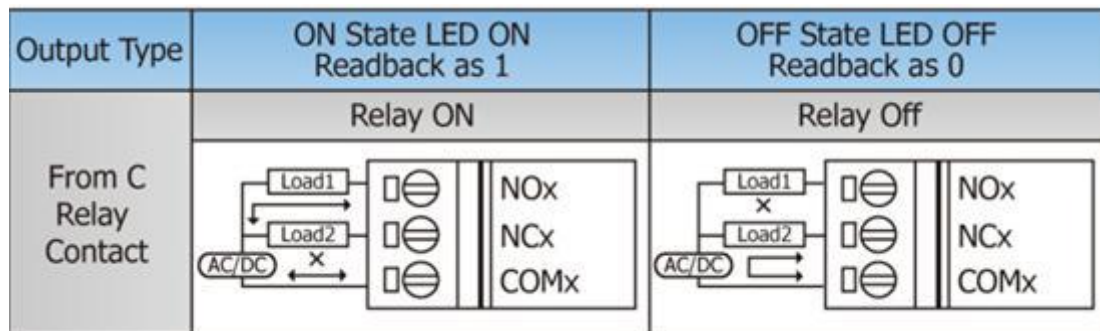

5.3 Analog Input

5.3.1 DN-AIO-M

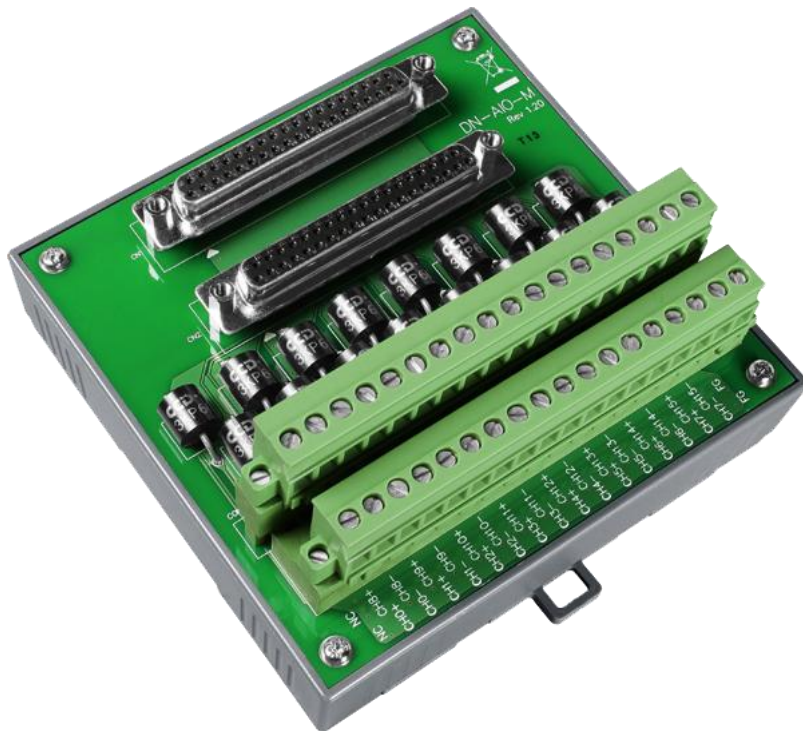

5.3.1.1 Overview

The DN-AIO-M is a termination board for analog input and output modules. It is a general termination board for most kind of analog modules. The size of this termination board is also small and same as other mini termination boards for users' installation.

5.3.1.2 Specification

Analog Input	
Channel	16
General	
Dimension (W x L x H)	112 x 117 x 29 mm
Mounting	35 mm DIN Rail, Wall
Operating temperature	-25 ~ 75°C
Humidity	5 ~ 95 % RH, Non-condensing

5.3.1.3 Pin assignment

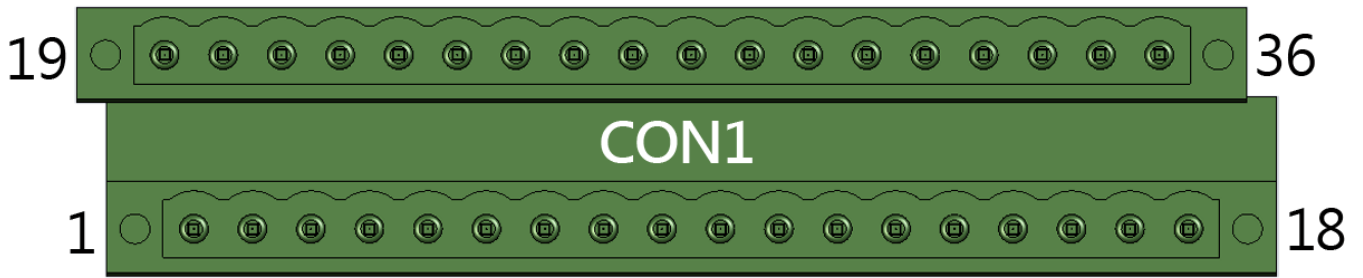

19	20	21	22	23	24	25	26	27	28	29	30	31	32	33	34	35	36
NC	CH8+	CH8-	CH9+	CH9-	CH10+	CH10-	CH11+	CH11-	CH12+	CH12-	CH13+	CH13-	CH14+	CH14-	CH15+	CH15-	FG
1	2	3	4	5	6	7	8	9	10	11	12	13	14	15	16	17	18
NC	CH0+	CH0-	CH1+	CH1-	CH2+	CH2-	CH3+	CH3-	CH4+	CH4-	CH5+	CH5-	CH6+	CH6-	CH7+	CH7-	FG

5.3.1.4 Wiring

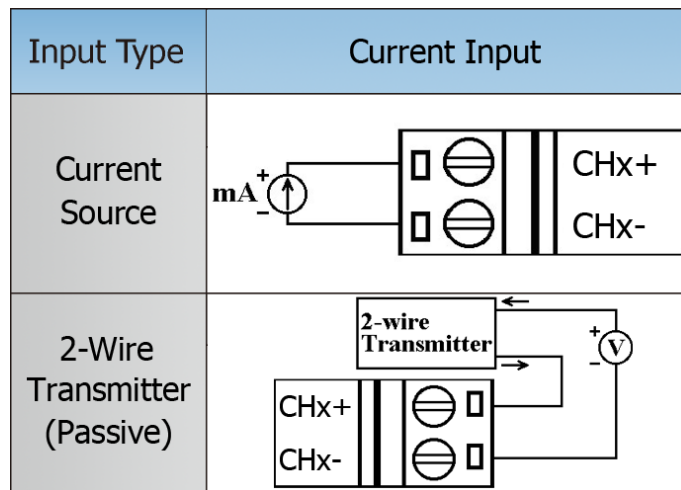
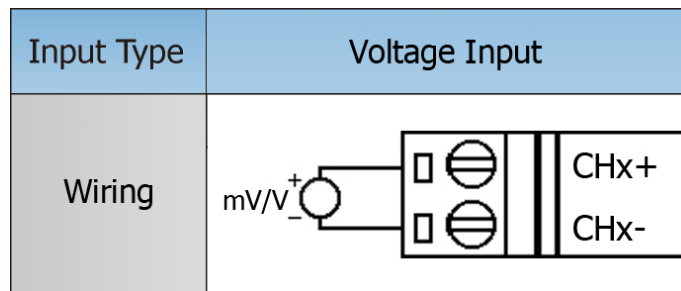

5.3.2 DN-RTD-M



5.3.2.1 Overview

The DN-RTD-M is a termination board for RTD input modules. The size of this termination board is also small and same as other mini termination boards for users' installation.

5.3.2.2 Specification

RTD Input	
Channel	8
General	
Dimension (W x L x H)	112 x 117 x 29 mm
Mounting	35 mm DIN Rail, Wall
Operating temperature	-25 ~ 75°C
Humidity	5 ~ 95 % RH, Non-condensing

5.3.2.3 Pin assignment

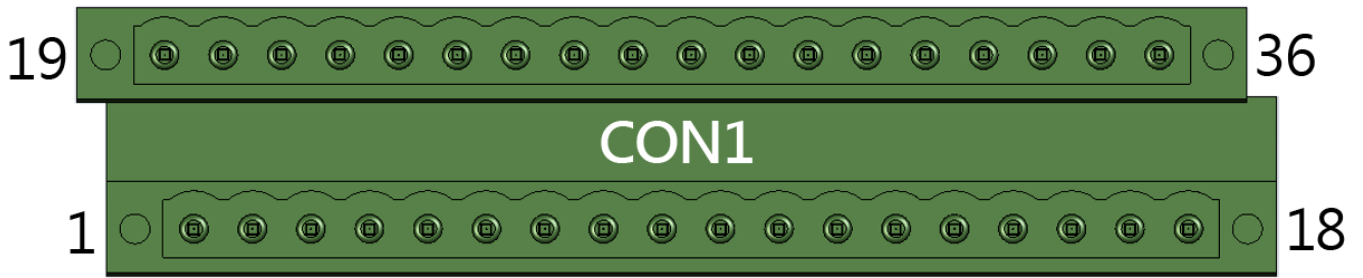

19	20	21	22	23	24	25	26	27	28	29	30	31	32	33	34	35	36
b9	A4	B4	b10	b11	A5	B5	b12	b13	A6	B6	b14	b15	A7	B7	b16	b17	FG
1	2	3	4	5	6	7	8	9	10	11	12	13	14	15	16	17	18
b0	A0	B0	b1	b2	A1	B1	b3	b4	A2	B2	b5	b6	A3	B3	b7	b8	FG

5.3.2.4 Wiring

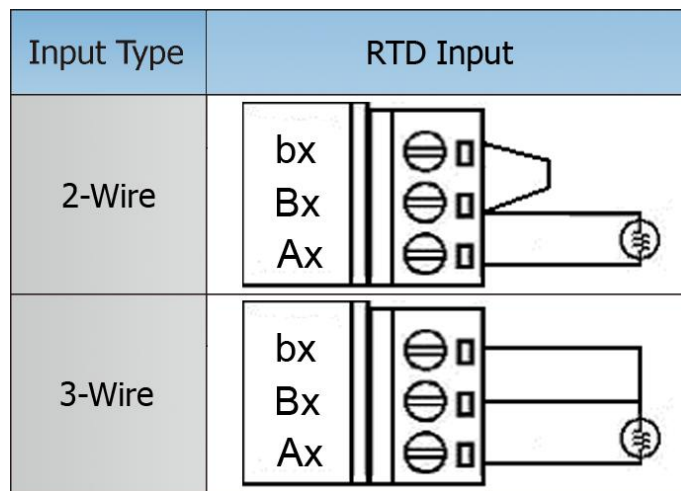

5.3.3 DN-TC-M



5.3.3.1 Overview

The DN-TC-M is a termination board for TC input modules. This termination board is also built-in CJC to measure temperature more accurate. The size of this termination board is also small and same as other mini termination boards for users' installation.

5.3.3.2 Specification

Thermocouple Input	
Channel	8
General	
Dimension (W x L x H)	112 x 117 x 29 mm
Mounting	35 mm DIN Rail, Wall
Operating temperature	-25 ~ 75°C
Humidity	5 ~ 95 % RH, Non-condensing

5.3.3.3 Pin assignment

CON1

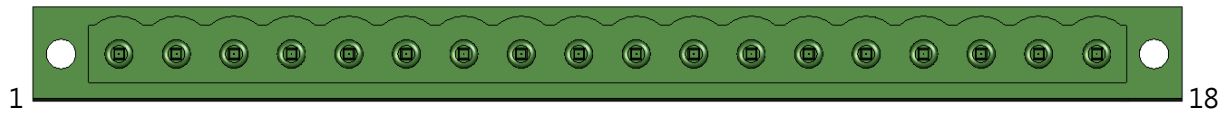

1	2	3	4	5	6	7	8	9	10	11	12	13	14	15	16	17	18
NC	CH0+	CH0-	CH1+	CH1	CH2+	CH2-	CH3+	CH3-	CH4+	CH4-	CH5+	CH5-	CH6+	CH6-	CH7+	CH7-	FG

5.3.3.4 Wiring

Input Type	Thermocouple Input
Voltage Input	
TC Input	

5.3.4 DN-AIH-08

This is left blank intentionally

5.3.4.1 Overview

The DN-AIH-08 is a termination board for HART analog input module. This termination board not only measures analog signal but also provides isolated power source for the field devices. In other words, this board supports both active and passive loop. Besides, this board also has short circuit protection for the isolated power, the loop current will be limited when circuit is shorted or the current is too large.

5.3.4.2 Specification

Analog Input	
Channel	8 (Support 2-Wire & 3-Wire connection)
Isolated Power Rating	1W with current limited protection
General	
Dimension (W x L x H)	135 x 214.6 x 25.5 mm
Mounting	35 mm DIN Rail, Wall
Operating temperature	-25 ~ 75°C
Humidity	5 ~ 95 % RH, Non-condensing

5.3.4.3 Pin assignment

CON2

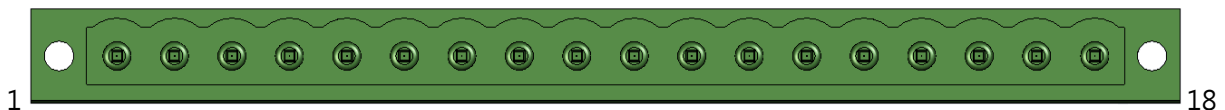

1	2	3	4	5	6	7	8	9	10	11	12	13	14	15	16	17	18
NC	CH0+	CH0-	PWR0	GND0	CH1+	CH1-	PWR1	GND1	CH2+	CH2-	PWR2	GND2	CH3+	CH3-	PWR3	GND3	FG

CON1

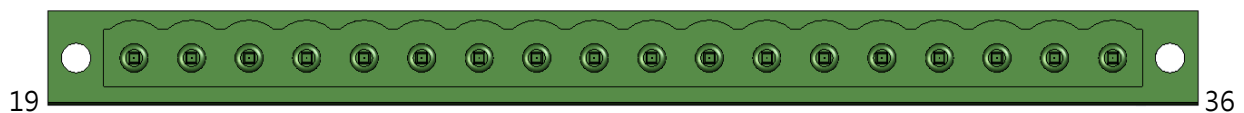

1	2	3	4	5	6	7	8	9	10	11	12	13	14	15	16	17	18
NC	CH4+	CH4-	PWR4	GND4	CH5+	CH5-	PWR5	GND5	CH6+	CH6-	PWR6	GND6	CH7+	CH7-	PWR7	GND7	FG

5.3.4.4 Wiring

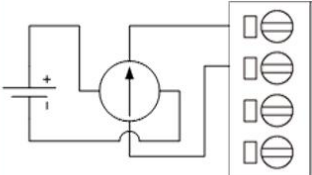
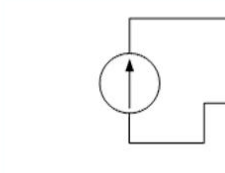
Input Type	HART Input
4-Wire Transmitter (Active)	 <p data-bbox="981 360 1093 533">CHx+ CHx- PWRx GNDx</p>
2-Wire Transmitter (Passive)	 <p data-bbox="981 562 1093 734">CHx+ CHx- PWRx GNDx</p>

5.4 Analog Output

5.4.1 DN-AIO-M

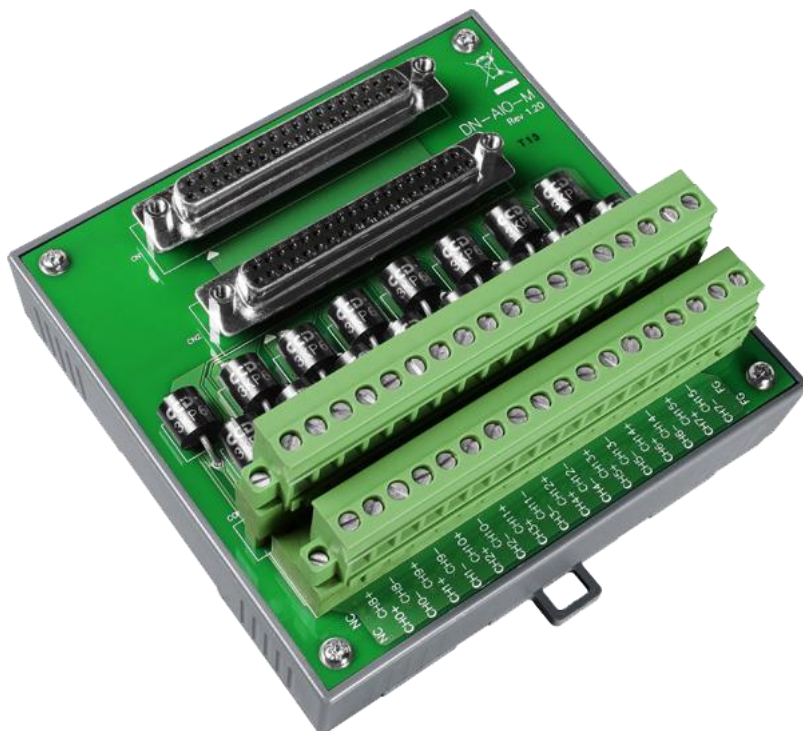

5.4.1.1 Overview

The DN-AIO-M is a termination board for analog input and output modules. It is a general termination board for most kind of analog modules. The size of this termination board is also small and same as other mini termination boards for users' installation.

5.4.1.2 Specification

Analog Output	
Channel	16
General	
Dimension (W x L x H)	112 x 117 x 29 mm
Mounting	35 mm DIN Rail, Wall
Operating temperature	-25 ~ 75°C
Humidity	5 ~ 95 % RH, Non-condensing

5.4.1.3 Pin assignment

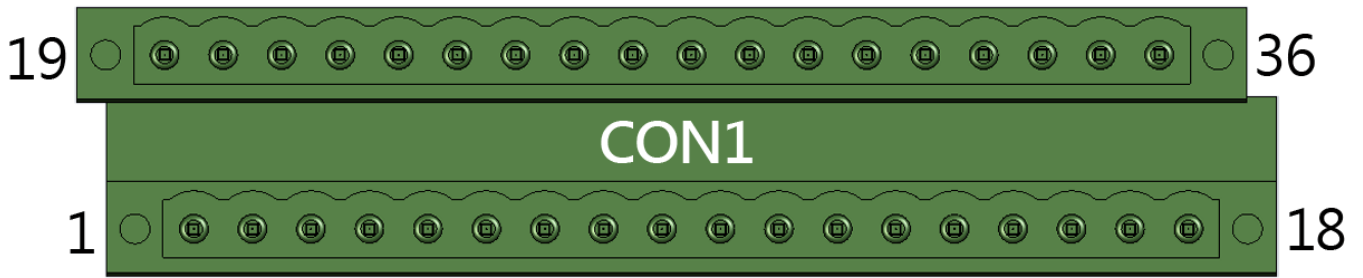

19	20	21	22	23	24	25	26	27	28	29	30	31	32	33	34	35	36
NC	CH8+	CH8-	CH9+	CH9-	CH10+	CH10-	CH11+	CH11-	CH12+	CH12-	CH13+	CH13-	CH14+	CH14-	CH15+	CH15-	FG
1	2	3	4	5	6	7	8	9	10	11	12	13	14	15	16	17	18
NC	CH0+	CH0-	CH1+	CH1-	CH2+	CH2-	CH3+	CH3-	CH4+	CH4-	CH5+	CH5-	CH6+	CH6-	CH7+	CH7-	FG

5.4.1.4 Wiring

Output Type	Analog Output
Voltage Output	
Current Output (HART)	

5.5 Pulse Input

5.5.1 DN-PI-M

This is left blank intentionally

5.5.1.1 Overview

The DN-PI-M is a termination board for pulse input modules. The size of this termination board is also small and same as other mini termination boards for users' installation.

5.5.1.2 Specification

Pulse Input	
Channel	8
General	
Dimension (W x L x H)	112 x 117 x 29 mm
Mounting	35 mm DIN Rail, Wall
Operating temperature	-25 ~ 75°C
Humidity	5 ~ 95 % RH, Non-condensing

5.5.1.3 Pin assignment

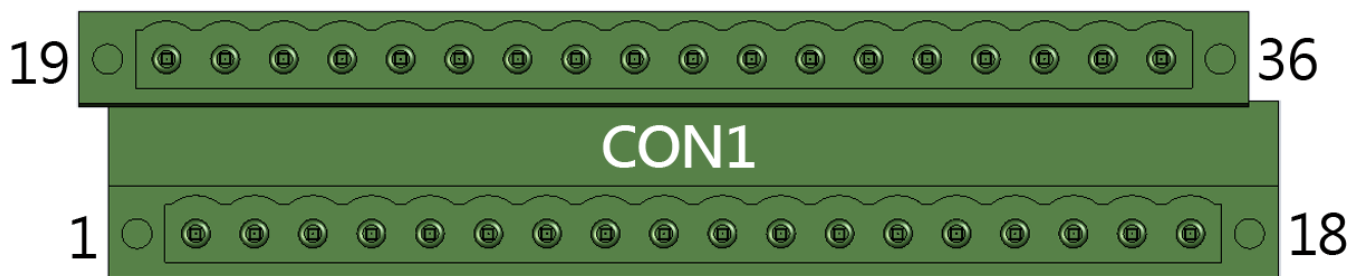

19	20	21	22	23	24	25	26	27	28	29	30	31	32	33	34	35	36
NC	CH4+	CH4-	PWR	NC	CH5+	CH5-	PWR	NC	CH6+	CH6-	PWR	NC	CH7+	CH7-	PWR	NC	FG
1	2	3	4	5	6	7	8	9	10	11	12	13	14	15	16	17	18
NC	CH0+	CH0-	PWR	NC	CH1+	CH1-	PWR	NC	CH2+	CH2-	PWR	NC	CH3+	CH3-	PWR	NC	FG

5.5.1.4 Wiring

Input Type	Pulse Input	Appropriate Impedance			
		None	200Ω	500Ω	1000Ω
Source NPN & Switch		✓	✗	✗	✗
Sink 24V		✓	✗	✗	✗
Sink Switch		✗	✓	✓	✓
Sink 2-wire transmitter		✗	✓	✓	✓
Sink 3-wire transmitter		✓	✗	✗	✗