

TN-5510A/5518A PoE Series

EN 50155 8+2G/16+2G-port Gigabit Ethernet switches with up to 8 PoE ports



- > 2 Gigabit ports with optional bypass relay function
- > Isolated power with wide 24 to 110 VDC power supply range
- > Essential compliance with EN 50155*
- > -40 to 75°C operating temperature range
- > Turbo Ring and Turbo Chain (recovery time < 20 ms @ 250 switches), and STP/RSTP/MSTP for network redundancy
- > 8 IEEE 802.3at/af compliant combo PoE and Ethernet ports
- > Provides up to 30 watts per PoE port

*Moxa defines "essential compliance" to include those EN 50155 requirements that make products more suitable for rolling stock railway applications.



Introduction

The ToughNet TN-5500A series M12 managed Ethernet switches are designed for railway applications, including rolling stock and wayside installations. The switches use M12 and other circular connectors to ensure tight, robust connections, and guarantee reliable operation in industrial environments where vibration and shock are commonplace. The TN-5500A series Ethernet switches have 8 or 16 Fast Ethernet M12 ports with 8 IEEE 802.3at/af compliant PoE (Power-over-Ethernet) ports and 2 ports on the down side to provide the Gigabit Ethernet interface with an optional bypass relay function. The PoE switches are classified as power source equipment (PSE); they provide up to 30 watts of power per port, and can be used to power IEEE 802.3at/af compliant powered

devices (PDs), such as IP cameras, wireless access points, and IP phones. The 24 to 110 VDC wide power input range and isolated power inputs not only allow you to use the same type of power source at different sites around the globe, but also increase the reliability of your communications system. Furthermore, the -40 to 75°C operating temperature and IP54-rated waterproof enclosure allow deployment in harsh environments. The TN-5500A series Ethernet switches are compliant with essential sections of EN 50155, covering operating temperature, power input voltage, surge, ESD, and vibration, as well as conformal coating and power insulation, making the switches suitable for a variety of industrial applications.

Features and Benefits

- Provides up to 30 watts per PoE port with a total power budget of 120 watts per switch
- IPv6 Ready logo awarded (IPv6 Logo Committee certified)
- Leading EN 50155-compliant PoE switches for rolling stock applications
- DHCP Option 82 for IP address assignment with different policies
- Turbo Ring and Turbo Chain (recovery time < 20 ms @ 250 switches), and STP/RSTP/MSTP for network redundancy
- IGMP snooping and GMRP for filtering multicast traffic
- EtherNet/IP and Modbus/TCP industrial Ethernet protocols supported
- Port-based VLAN, IEEE 802.1Q VLAN, and GVRP to ease network planning
- QoS (IEEE 802.1p/1Q and ToS/DiffServ) allows real-time traffic classification and prioritization
- IEEE 802.3ad, LACP for optimum bandwidth utilization
- SNMPv1/v2c/v3 for different levels of network management
- TACACS+, SNMPv3, IEEE 802.1X, HTTPS, and SSH to enhance network security
- RMON for efficient network monitoring and proactive capability
- Bandwidth management prevents unpredictable network status
- Lock port allows access by only authorized MAC addresses
- Port mirroring for online debugging
- Automatic warning by exception through email and relay output
- Line-swap fast recovery
- LLDP for automatic topology discovery in network management software
- Configurable by web browser, Telnet/serial console, CLI, and Windows utility
- Loop protection prevents network loops
- Panel mounting or DIN-rail mounting installation capability

Specifications

Technology

Standards:

IEEE 802.3 for 10BaseT
 IEEE 802.3u for 100BaseT(X)
 IEEE 802.3ab for 1000BaseT(X)
 IEEE 802.3x for Flow Control
 IEEE 802.1D-2004 for Spanning Tree Protocol
 IEEE 802.1w for Rapid Spanning Tree Protocol
 IEEE 802.1s for Multiple Spanning Tree Protocol
 IEEE 802.1Q for VLAN Tagging
 IEEE 802.1p for Class of Service
 IEEE 802.1X for Authentication
 IEEE 802.3ad for Port Trunk with LACP

Protocols: IGMPv1/v2, GMRP, GVRP, SNMPv1/v2c/v3, DHCP Server/Client, DHCP Option 66/67/82, BootP, TFTP, SNTP, SMTP, RARP, RMON, HTTP, HTTPS, Telnet, SSH, Syslog, SNMP Inform, LLDP, IEEE 1588 PTP v2, IPv6, NTP Server/Client, EtherNet/IP, Modbus/TCP
MIB: MIB-II, Ethernet-like MIB, P-BRIDGE MIB, Q-BRIDGE MIB, Bridge MIB, RSTP MIB, RMON MIB Group 1, 2, 3, 9

Flow Control: IEEE 802.3x flow control, back pressure flow control

Switch Properties

Priority Queues: 4

Max. Number of Available VLANs: 64

VLAN ID Range: VID 1 to 4094

IGMP Groups: 256

Interface

Fast Ethernet: Front cabling, M12 D-coded 4-pin female connector, 10/100BaseT(X) auto negotiation speed, F/H duplex mode, and auto MDI/MDI-X connection

Gigabit Ethernet: Down cabling, M12 X-coded 8-pin female connector, 10/100/1000BaseT(X) auto negotiation speed, F/H duplex mode, auto MDI/MDI-X connection, with or without bypass relay function

Console Port: M12 A-coding 5-pin male connector

System LED Indicators: PWR1, PWR2, FAULT, MSTR/HEAD, CPLR/TAI

Port LED Indicators: 10/100M (Fast Ethernet port), 10/100/1000M (Gigabit Ethernet port), PoE

Alarm Contact: 2 relay outputs in one M12 A-coding 5-pin male connector with current carrying capacity of 1 A @ 30 VDC

Power Requirements

Input Voltage:

WV: 24 to 110 VDC (16.8 to 137.5 VDC)

Max. Input Current:

TN-5510A-8PoE: TBD @ 24 VDC; TBD @ 110 VDC
 TN-5518A-8PoE: 8.66 A @ 24 VDC; 1.69 A @ 110 VDC

Overload Current Protection: Present

Connection: M23 connector

Reverse Polarity Protection: Present

Physical Characteristics

Housing: Aluminium alloy, IP54 protection (optional protective caps available for unused ports)

Dimensions:

TN-5510A-8PoE: 185 x 180.9 x 115 mm (7.28 x 7.12 x 4.53 in)
 TN-5518A-8PoE: 250 x 180.9 x 115 mm (9.84 x 7.12 x 4.53 in)

Weight:

TN-5510A-8PoE: 2,551 g
 TN-5518A-8PoE: 3,439 g

Installation: Panel mounting, DIN-rail mounting (with optional kit: DK-DC50131)

Environmental Limits

Operating Temperature: -40 to 75°C (-40 to 167°F)

Storage Temperature: -40 to 85°C (-40 to 185°F)

Ambient Relative Humidity: 5 to 95% (non-condensing)

Vibration:

IEC 60068-2-6, 2-17.8 Hz: ±1.6 mm; 17.8-500 Hz: 2 g; 2 hours/axis

Shock: IEC 60068-2-27, 20 g / 11 ms

Ingress Protection: IEC 60529, IP54

Altitude: Up to 2,000 m

Note: Please contact Moxa if you require products guaranteed to function at higher altitudes

Standards and Certifications

Safety: UL/cUL 508, EN 60950-1 (LVD)

EMC: EN 55022, EN 55024

EMI: CISPR 22, FCC Part 15B Class A

EMS:

IEC 61000-4-2 ESD: Contact 6 kV; Air 8 kV
 IEC 61000-4-3 RS: 20 V/m (80 MHz to 1 GHz)
 IEC 61000-4-4 EFT: Power 2 kV; Signal 2 kV
 IEC 61000-4-5 Surge: Power 2 kV; Signal 2 kV
 IEC 61000-4-6 CS: 10 V
 IEC 61000-4-8

Rail Traffic: (for panel mounting installations)

EN 50155 (essential compliance*), EN 50121-4, EN 50121-3-2, EN 45545-2

**Please contact Moxa or a Moxa distributor for details.*

Shock: IEC 61373

Freefall: IEC 60068-2-32

Vibration: EN 50155, IEC 61373

MTBF

Time:

TN-5510A-8PoE-2GTX: TBD
 TN-5510A-8PoE-2GTXP: TBD
 TN-5518A-8PoE-2GTX: 448,300 hrs
 TN-5518A-8PoE-2GTXP: 439,442 hrs

Standard: Telcordia SR332, GB, 25°C

Note: Please check Moxa's website for the most up-to-date certification status.

Warranty

Warranty Period: 5 years

Details: See www.moxa.com/warranty

Dimensions

Unit: mm (inch)

TN-5510A-8PoE Series

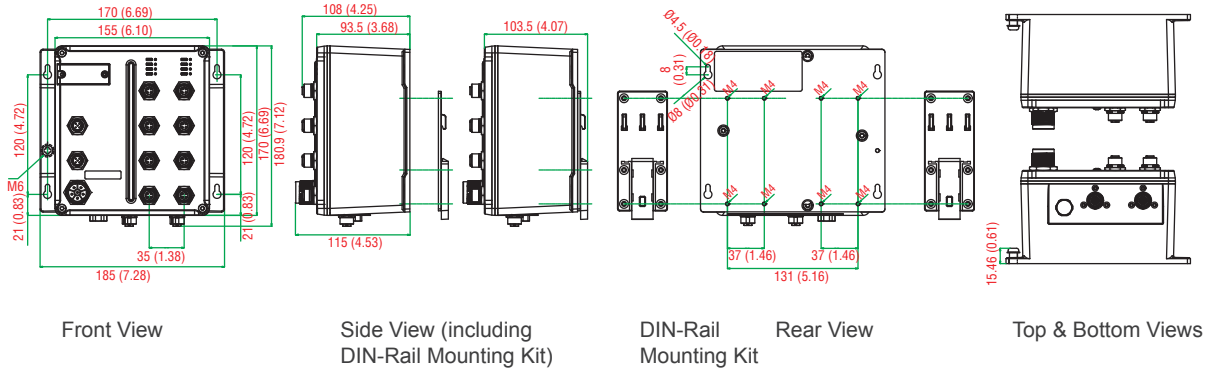

TN-5518A-8PoE Series

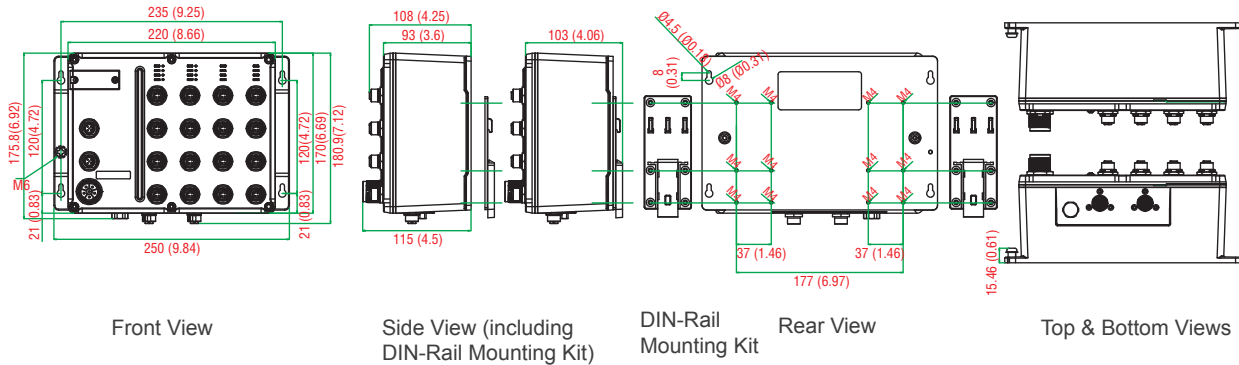

Ordering Information

Available Models	Port Interface				Power Supply	Conformal Coating
	Front Cabling		Down Cabling			
Wide Temperature (-40 to 75°C)	PoE, 10/100 BaseT(X), M12 connector	10/100 BaseT(X), M12 connector	10/100/1000 BaseT(X), M12 connector	10/100/1000 BaseT(X), M12 connector with bypass relay	WV: 24 to 110 VDC (16.8 to 137.5 VDC)	
TN-5510A-8PoE Series						
TN-5510A-8PoE-2GTX-WV-T	8	-	2	-	1	-
TN-5510A-8PoE-2GTX-WV-CT-T	8	-	2	-	1	✓
TN-5510A-8PoE-2GTXBP-WV-T	8	-	-	2	1	-
TN-5510A-8PoE-2GTXBP-WV-CT-T	8	-	-	2	1	✓
TN-5518A-8PoE Series						
TN-5518A-8PoE-2GTX-WV-T	8	8	2	-	1	-
TN-5518A-8PoE-2GTX-WV-CT-T	8	8	2	-	1	✓
TN-5518A-8PoE-2GTXBP-WV-T	8	8	-	2	1	-
TN-5518A-8PoE-2GTXBP-WV-CT-T	8	8	-	2	1	✓

Optional Accessories (must be purchased separately)

Power Cords, M12/M23 Connectors, Protective Caps: See following page
MXview: Moxa industrial network management software with 50, 100, 250, 500, 1000, or 2000 nodes
EDS-SNMP OPC Server Pro: OPC server software that works with all SNMP devices
ABC-01-M12: Configuration backup and restoration tool for TN series managed Ethernet switches, 0 to 60°C operating temperature

Package Checklist

- TN-5500A switch
- M12-to-DB9 console port cable
- 2 protective caps for console and relay output ports
- Panel mounting kit
- Documentation and software CD
- Hardware installation guide
- Warranty card

EN 50155 Switch Accessories

: M12/M23 Power Cords

CBL-M12D(MM4P)/RJ45-100 IP67

1-meter M12-to-RJ45 Cat-5C UTP Ethernet cable with IP67-rated 4-pin male D-coded M12 connector



CBL-M12(FF5P)/OPEN-100 IP67

1-meter M12-to-5-pin power cable with IP67-rated 5-pin female A-coded M12 connector



CBL-M23(FF6P)/Open-BK-100 IP67

1-meter M23-to-6-pin power cable with IP67-rated 6-pin female M23 connector



: M12 Connectors

M12D-4P-IP68

Field-installable M12 D-coded screw-in sensor connector, 4-pin male, IP68-rated



M12A-5P-IP68

Field-installable M12 A-coded screw-in sensor connector, 5-pin female, IP68-rated



: M12 IP67 Protective Caps

A-CAP-M12F-M

Metal cap for M12 female connector



A-CAP-M12M-M

Metal cap for M12 male connector

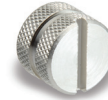

: M23 Connectors

A-PLG-WPM23-01

M23 cable connector, 6-pin female, crimp type

